

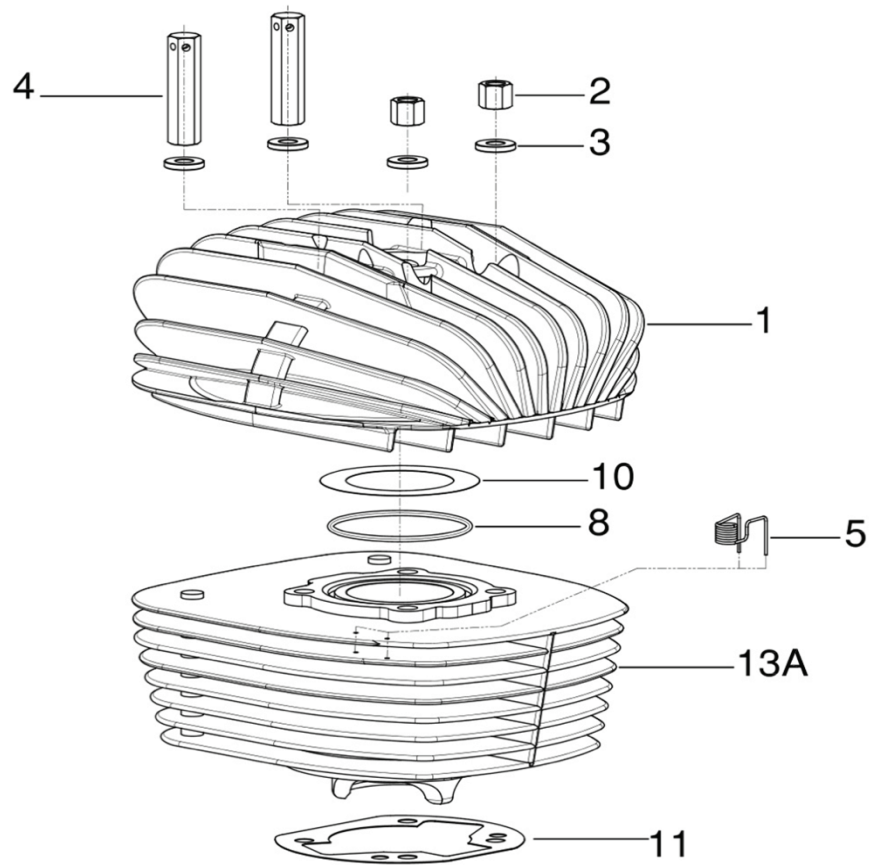

KA100 REEDJET - 100cc USA





RJA-001

POS	PART #	DESCRIPTION	USA RETAIL
1	IAA-40100-2	CYLINDER HEAD KA100	\$ 285.81
2	10350	HEAD NUT	\$ 3.56
3	10635	HEAD NUT WASHER H=3mm	\$ 1.81
4	10351	LONG CYLINDER HEAD NUT W/TECH WIRE HOLE	\$ 15.86
5	10787	SPARK PLUG LEAD RETAINING SPRING	\$ 8.70
8	D-37049	HEAD GASKET O-RING	\$ 6.84
10	IAA-40200-0.05	COPPER HEAD GASKET 0.05	\$ 3.03
10	IAA-40200-0.10	COPPER HEAD GASKET 0.10	\$ 3.03
10	IAA-40200-0.15	COPPER HEAD GASKET 0.15	\$ 3.03
11	EBP-125045	CYL. GASKET 4/10 SUD-TOP/X30	\$ 3.56
11	EBP-125046	CYL. GASKET 2/10 SUD-TOP/X30	\$ 3.56
11	EBP-125047	CYL. GASKET 1/10 SUD-TOP/X30	\$ 6.64
11	EBP-125048	CYL. GASKET 5/100 SUD-TOP/X30	\$ 6.64
13A	IAA-01000/1	CYLINDER REEDJET KA100	\$ 641.20

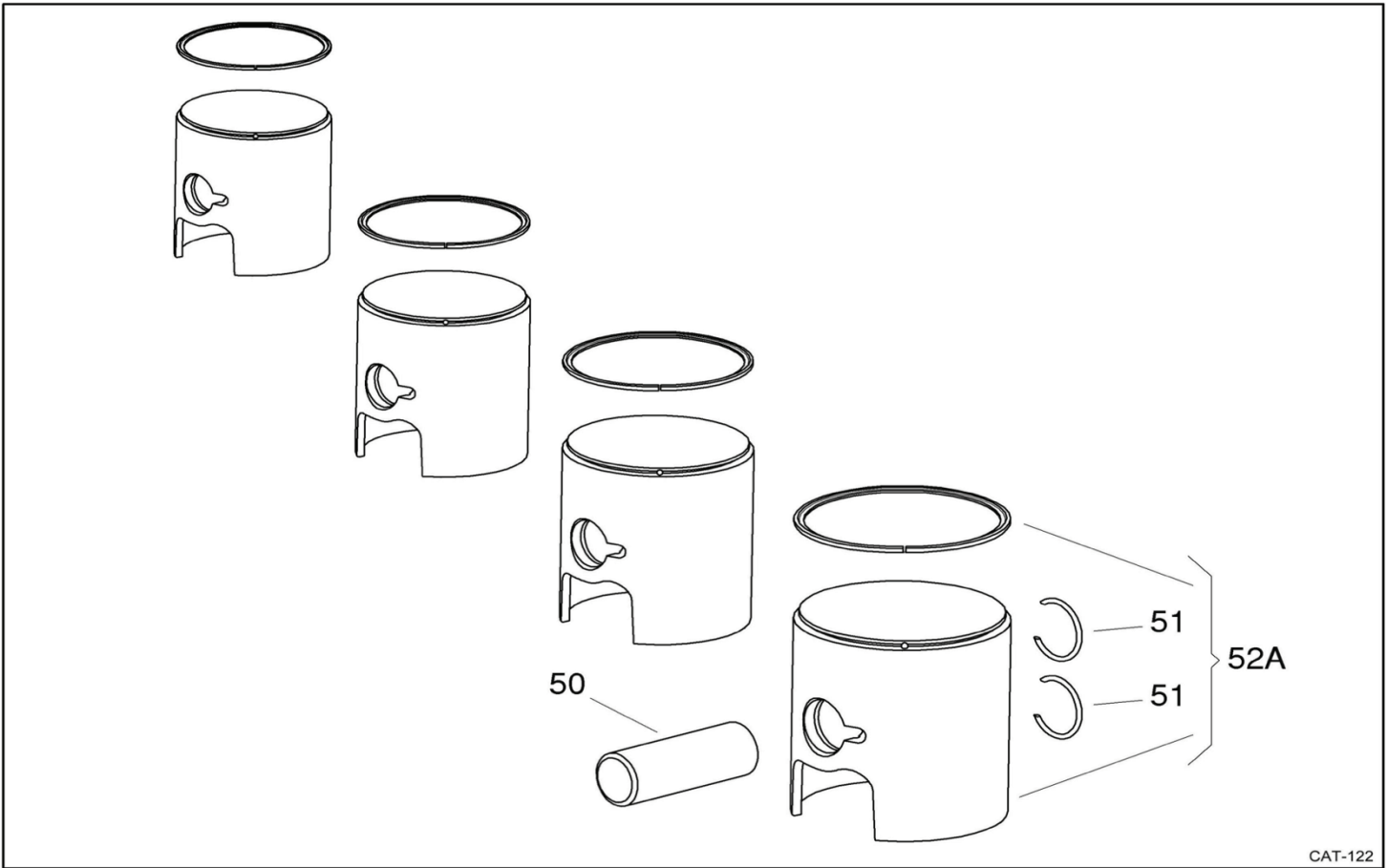

CAT-122

POS	PART #	DESCRIPTION	USA RETAIL
50	B-10321-B	PISTON PIN - 14x39 "B"	\$ 32.16
50	B-10321-R	PISTON PIN - 14x39 "R"	\$ 32.16
51	10343	CIRCLIP 1.0mm	\$ 1.88
52A	EBP-85050-CV	PISTON KA 48.20g	\$ 120.65
52A	EBP-85055-CV	PISTON KA 48.22g	\$ 120.65
52A	EBP-85057-CV	PISTON KA 48.24g	\$ 120.65
52A	EBP-85060-CV	PISTON KA 48.26g	\$ 120.65
52A	EBP-85063-CV	PISTON KA 48.28g	\$ 120.65
52A	EBP-85065-CV	PISTON KA 48.30g	\$ 120.65
52A	EBP-85070-CV	PISTON KA 48.32g	\$ 120.65
52A	EBP-85072-CV	PISTON KA 48.34g	\$ 120.65
52A	EBP-85075-CV	PISTON KA 48.36g	\$ 120.65
52A	EBP-85080-CV	PISTON KA 48.40g	\$ 120.65
52A	EBP-85085-CV	PISTON KA 48.42g	\$ 120.65
52A	EBP-85087-CV	PISTON KA 48.44g	\$ 120.65
52A	EBP-85090-CV	PISTON KA 48.46g	\$ 120.65
52A	EBP-85093-CV	PISTON KA 48.48g	\$ 120.65
52A	EBP-85095-CV	PISTON KA 48.50g	\$ 120.65
52A	EBP-85100-CV	PISTON KA 48.52g	\$ 120.65
53	B-65175	PISTON RING KA 48.20	\$ 44.31
53	B-65178	PISTON RING KA 48.26	\$ 44.31
53	B-65180	PISTON RING KA 48.30	\$ 44.31
53	B-65183	PISTON RING KA 48.36	\$ 44.31
53	B-65185	PISTON RING KA 48.40	\$ 44.31
53	B-65188	PISTON RING KA 48.46	\$ 44.31
53	B-65190	PISTON RING KA 48.50	\$ 44.31

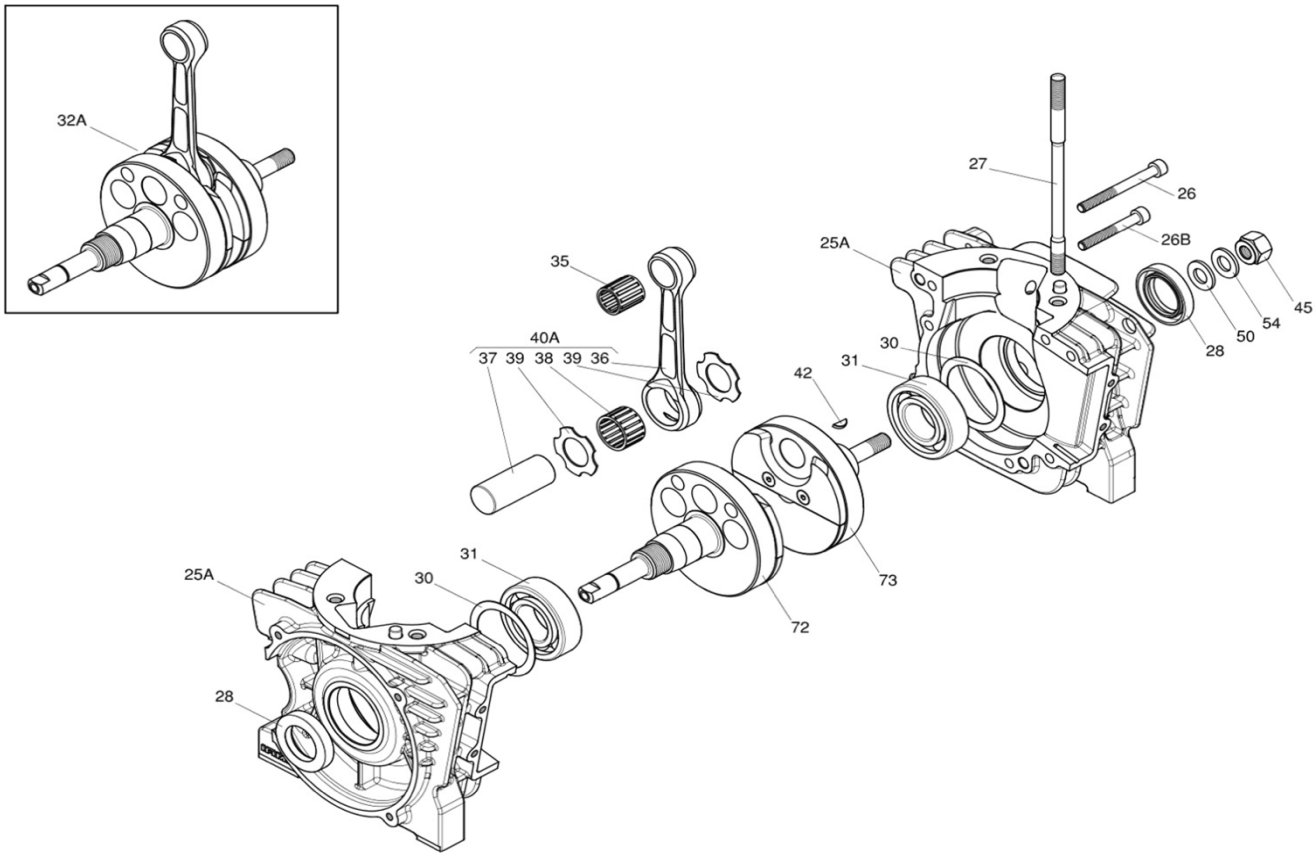

CAT-294

POS	PART #	DESCRIPTION	USA RETAIL
25A	IAB-01041/1	CRANKCASE ASSY KA100	\$ 709.56
26	00051-K	KIT OF 20 ALLEN SCREWS 6x55	\$ 10.00
26B	00049-K	KIT OF 20 ALLEN SCREWS 6x45	\$ 7.18
27	E-38345	CYLINDER TIE-ROD 8x157	\$ 13.90
28	X30125425A	OIL SEAL MAGN./DRIVE SIDE	\$ 15.00
30	30404	STEEL SHIM 0.15	\$ 3.56
30	30407	STEEL SHIM 0.10	\$ 3.56
31	35396-G	BALL BEARING 6205 TNH/C4	\$ 20.44
32A	IAC-00100	CRANK SHAFT ASSY - KA100	\$ 814.34
35	E-10440	SMALL END ROLLER CAGE - SILVER	\$ 34.92
35	E-10441	SMALL END ROLLER CAGE - BLACK	\$ 34.92
36	IFC-50100	CONROD BARE KA	\$ 308.72
37	IAC-40140	CRANKPIN 20x47mm	\$ 33.74
38	X30125431	BIG END CAGE	\$ 67.02
39	X30125436	SILVER BRONZE WASHER	\$ 10.40
40A	ENC50100-47	CON-ROD ASSY 102mm / PIN 47 KA	\$ 341.93
40A	IFC-50100-47	CON-ROD ASSY 102mm / PIN 47 KA	\$ 413.16
42	10375	MAGNETO/SPROCKET SHAFT END KEY	\$ 2.43
45	00382	NUT M10x1	\$ 2.29
50	00305-K	KIT OF 20 WASHERS M10	\$ 7.47
54	00342-K	KIT 20 WASHERS 10,5x18x0,8	\$ 6.66
72	GBP-125386	HALF CRANK PTO KA100	\$ 318.22
73	IAC-30141	HALFCR. IG.S. DRAG/LEOP MY '09	\$ 248.90
74	DBP-09505-K	CRANK PLASTIC STUFFER KIT (1 Piece + Screws)	\$ 14.95

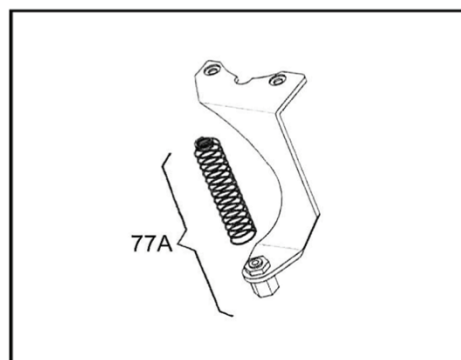
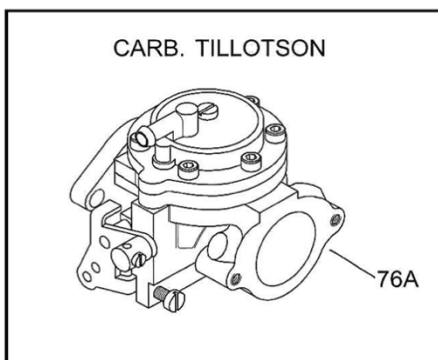
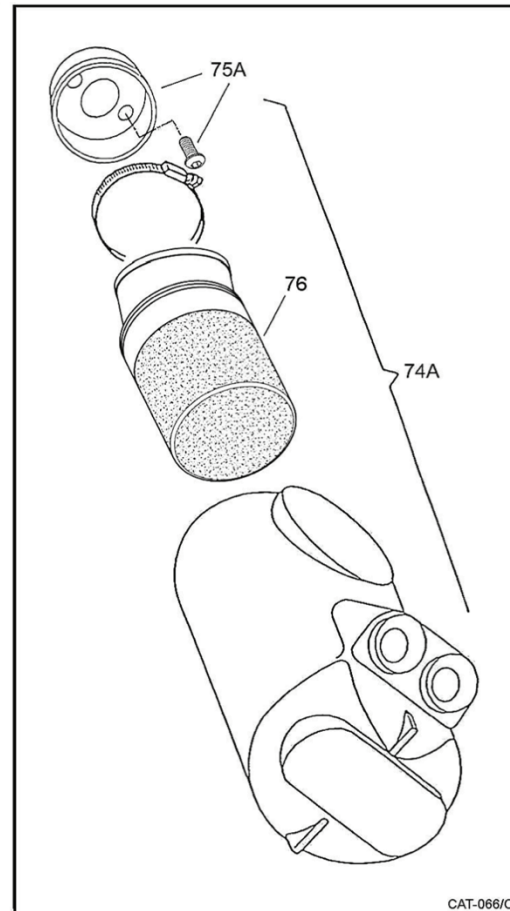
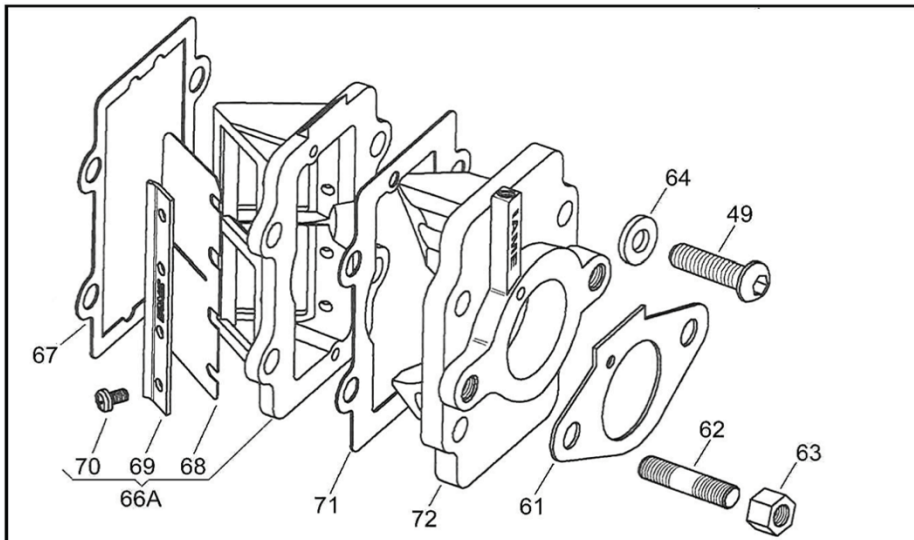

POS	PART #	DESCRIPTION	USA RETAIL
49	00045-K	KIT 20 SOCKET H. SCREWS M6X25	\$ 4.57
61	10360-B	CARBURETOR GASKET	\$ 3.76
62	10525	FIX.CARB.STUDBOLT 6x25	\$ 5.08
63	00351-K	20 HEXAGONAL NUTS KIT M6	\$ 3.56
64	00302-K	KIT 20 WASHERS M6	\$ 1.81
66A	X3011830-C	FIBERGLASS REED BLOCK ASSY W/FGLASS REEDS	\$ 94.38
67	X30125810A	REED BLOCK GASKET X30	\$ 5.08
68	X3011840	FIBERGLASS REED PETAL	\$ 17.09
69	F-11845A	REED CLIPS	\$ 3.56
70	10380-K	KIT 20 SCREWS 1/2 CR.HEAD 3X5	\$ 35.43
71	X30125809A	TOP CONVEYOR GASKET X30	\$ 7.03
72	X30125815A	CONVEYOR/MANIFOLD 28mm	\$ 74.03
74A	IAG-90000	AIRBOX KA	\$ 52.98
74A	IAG-90000G	INLET SILENCER SOCOREM W/MANIFOLD/FILTER	\$ 83.25
	IAG-90000-W	INLET SILENCER RAIN COVER - KA	\$ 52.42
76	10751-A	RUBBER HOSE WITH FOAM FILTER	\$ 43.96
	10751	RUBBER CONNECTOR WITH NO FOAM FILTER - FOR RAIN USE	\$ 38.30
76A	TI-HW-33A	CARBURETTOR TILL. HW33A	\$ 289.95
77A	IAG-50200	ACCELERATOR CABLE RETURN SPRING	\$ 5.36

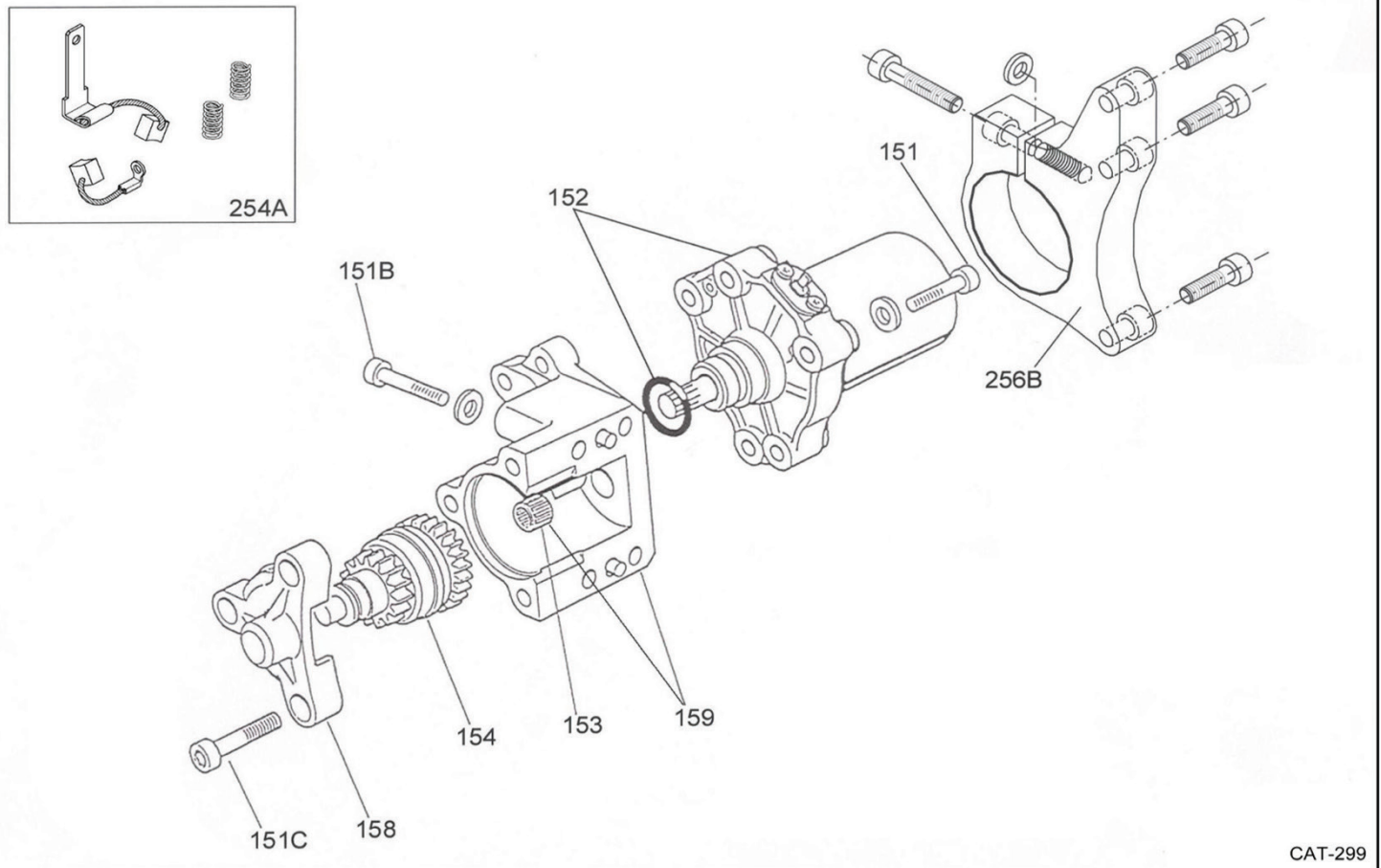

POS	PART #	DESCRIPTION	USA RETAIL
151	00047-K	KIT OF 20 ALLEN SCREWS 6x35	\$ 7.18
151B	00049-K	KIT OF 20 ALLEN SCREWS 6x45	\$ 7.18
151C	00045-K	KIT 20 SOCKET H. SCREWS M6X25	\$ 4.57
152	A-120851A	STARTER MOTOR	\$ 270.29
153	A-60865	ROLLER CAGE TaG	\$ 11.28
154	A-120856	BENDIX	\$ 122.91
158	A-60870	BENDIX SUPPORT	\$ 17.09
159	A-120860A-C	BENDIX HOUSING WITH ROLLER	\$ 117.95
254A	A-60852A-C	STARTER BRUSHES KIT	\$ 30.91
256B	A-125863-C	STARTER SUPPORT - LEOP/MY'09 LEOP/KA100	\$ 43.12
	A-60940	STARTER TERMINAL & BOOT	\$ 6.19

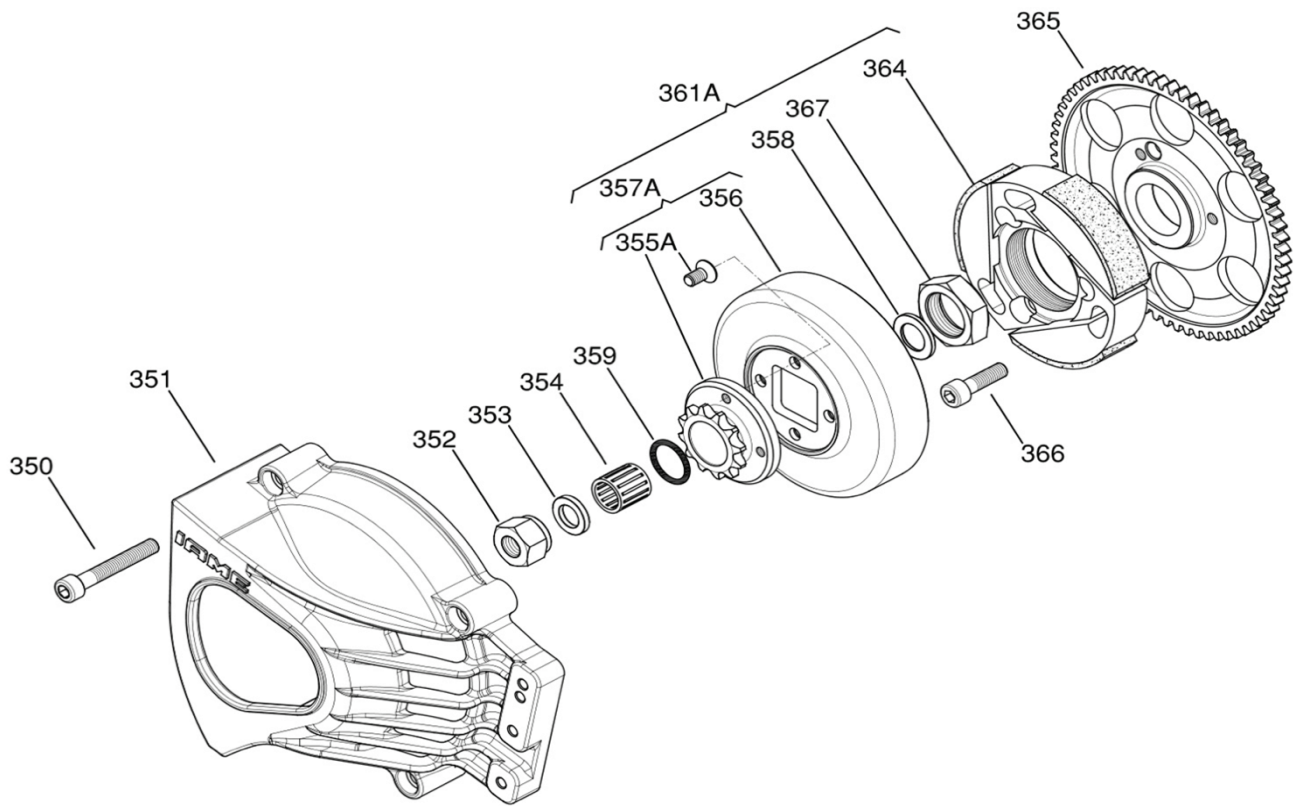

RJA-006

POS	PART #	DESCRIPTION	USA RETAIL
350	00046-K	KIT 20 SCREWS M6x30	\$ 7.47
351	A-60595BN	CLUTCH GUARD KA100 BLACK	\$ 54.05
352	D-75570	STARTER NUT TaG	\$ 7.13
352	X3012553-US	SPECIAL NUT & WASHER FOR Z9 SPROCKET	\$ 12.23
353	D-75573	EXTERNAL WASHER	\$ 3.56
354	B-55598	CLUTCH ROLLER CAGE - SHORT (USE WITH O RING)	\$ 13.33
354	D-75598	CLUTCH ROLLER CAGE - LONG	\$ 13.33
354	S1145/3	BUSHING FOR Z9 SPROCKET	\$ 9.61
355A	X30125553-C	SPROCKET Z9 W/SCREWS	\$ 68.08
355A	X30125554-C	SPROCKET Z10 W/SCREWS	\$ 68.08
355A	X30125555-C	SPROCKET Z11 W/SCREWS	\$ 68.08
355A	X30125556-C	SPROCKET Z12 W/SCREWS	\$ 68.08
355A	X30125557-C	SPROCKET Z13 W/SCREWS	\$ 68.08
355A	X30125558-C	SPROCKET Z16 W/SCREWS	\$ 79.82
356	X30125550A	CLUTCH DRUM-NO HOLES X30/KA	\$ 71.33
357A	X30125550A-C10	CLUTCH DRUM BLIND + SPR Z10	\$ 151.22
357A	X30125550A-C11	CLUTCH DRUM-NO HOLES + Z11 SPR	\$ 151.22
357A	X30125550A-C12	CLUTCH DRUM BLIND + SPR Z12	\$ 151.22
358	D-75565	THRUST INT. WASHER H=1,8mm	\$ 5.08
359	A-60565	CLUTCH DRUM O-RING	\$ 2.20
361A	X30125841-C10	COMPLETE CLUTCH ASSY Z10	\$ 314.40
361A	X30125841-C11	COMPLETE CLUTCH ASSY Z11	\$ 314.40
361A	X30125841-C12	COMPLETE CLUTCH ASSY Z12	\$ 314.40
364	X30125841	PADDED HUB X30 '13	\$ 180.56
365	IAI-30000	START.WHEEL REEDJ-AU/LEOP MY09	\$ 116.04
366	00042-K	KIT OF 20 M6x16 TECNIC BOLTS	\$ 4.57
367	IFF-21300	WHEEL LOCKING NUT	\$ 17.72

EXHAUST GROUP & GASKETS

KA100

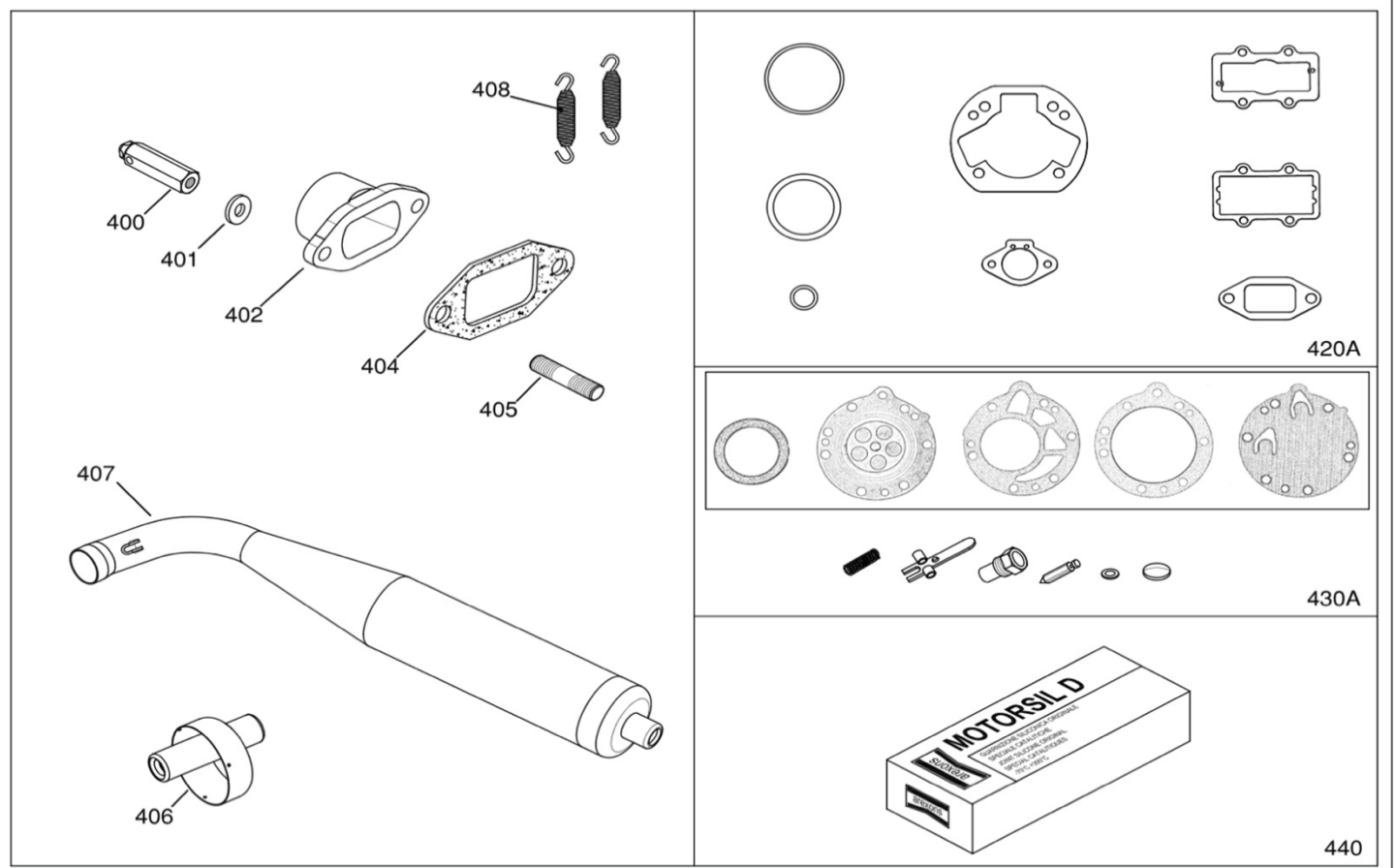

440
RJA-011

POS	PART #	DESCRIPTION	USA RETAIL
400	IAA-20300	EXHAUST NUT LONG W/TECH WIRE HOLE	\$ 8.98
401	00303-K	KIT OF 20 WASHERS M8	\$ 1.90
402	IAH-02000	EXHAUST HEADER SENIOR KA100	\$ 66.63
402	IAH-02011	EXHAUST HEADER JUNIOR KA100 22mm	\$ 66.63
404	B-75360	EXHAUST GASKET	\$ 8.35
405	B-75355	EXHAUST STUDBOLT 8x36	\$ 8.35
406	IAH-04301	SILENCER END CAP KA100	\$ 42.42
407	IAH-04000	EXHAUST SILENCER KA100	\$ 272.80
408	IFH-55100	FLEXIBLE SPRING KF1-2 / KZ	\$ 9.32
420A	IAZ-125992	GASKET SET KA100	\$ 41.13
430A	RK3HW	GASKET AND DIAPHRAGM KIT - CARB	\$ 14.95
430A	TI-RK-6HW	REPAIR KIT - HW-27A/33A (X30/KA)	\$ 32.95
440	00602	GASKET AREXON	\$ 43.59

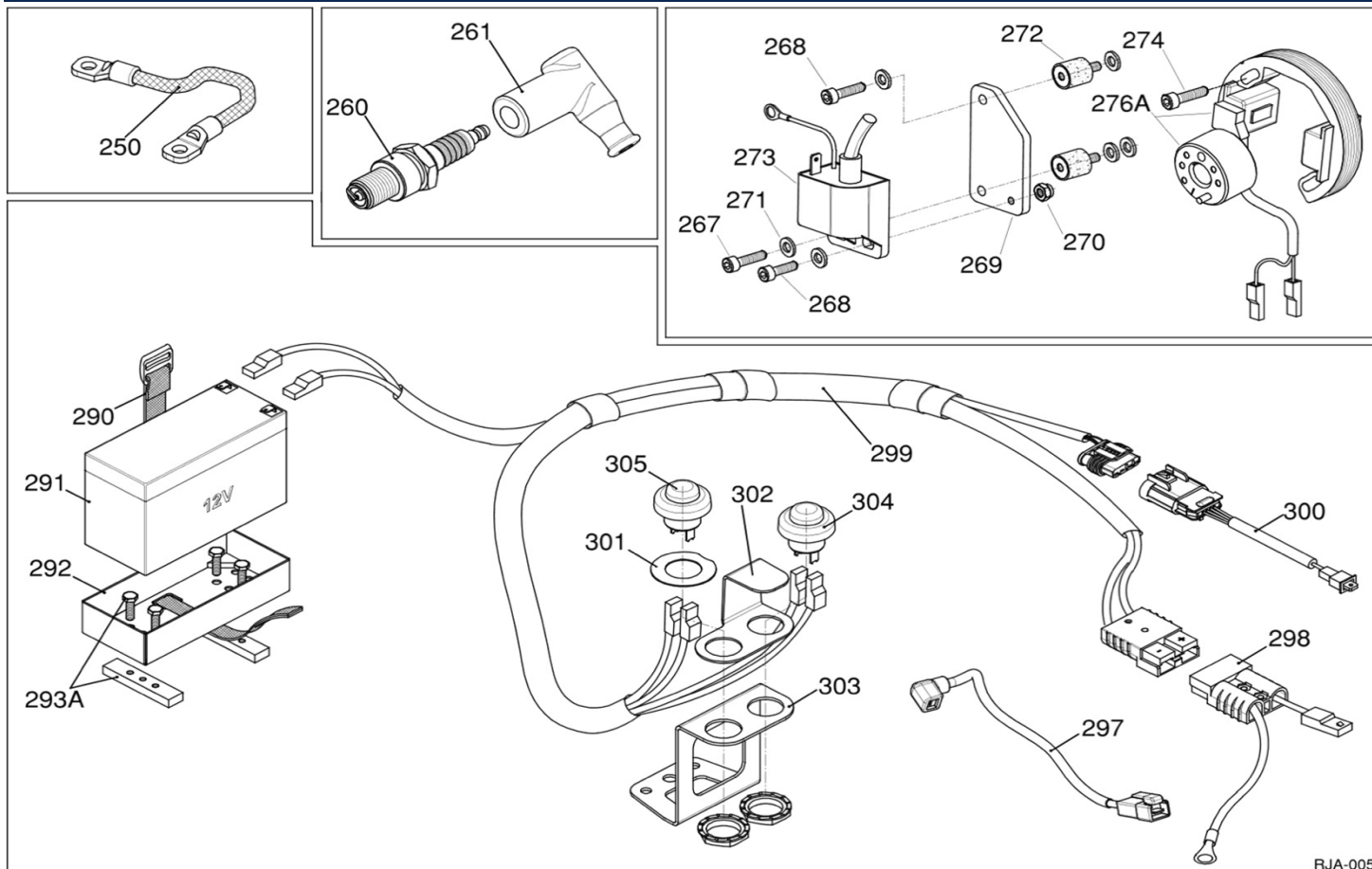

RJA-005

POS	PART #	DESCRIPTION	USA RETAIL
260	10561-A	SPARK PLUG NGK BR10EG	\$ 12.95
261	10544	IAME SPARK PLUG CAP BLACK	\$ 13.00
267	00032-K	KIT OF 20 SCREWS TCCE 5x20	\$ 4.88
268	00031-K	KIT OF 20 ALLEN SCREWS M5x16	\$ 5.08
269	A-61510	COIL SUPPORT	\$ 22.08
270	00378-K	20 SELF LOCKING NUTS KIT M6	\$ 4.57
271	00301-K	KIT 20 WASHERS M5	\$ 1.81
272	A-61520	COIL VIBRATION DAMPING	\$ 11.76
273	A-61955	COIL SELET. BLACK MINI/KA	\$ 106.99
274	00034-K	KIT OF 20 ALLEN SCREWS 5x25	\$ 4.57
276A	A-61951A	IGNITION STATOR ASSY KA	\$ 172.36
290	A-60904A	BATTERY FIXING BELT	\$ 17.09
292	X30125905	BATTERY SUPPORT	\$ 41.11
293A	A-60907A-C	BATTERY SUPPORT CLAMP 30mm W/SCREWS	\$ 33.23
297	IFE-05600	STARTER CABLE	\$ 18.84
298	IFE-05401D	STARTER MOTOR CABLE	\$ 33.91
299	IFE-05004	CABLE HARNESS DIG. S	\$ 127.32
300	IAE-06100	IGNITION ADAPTER	\$ 15.52
302	IFI-70101	SECURITY BRACKET	\$ 15.86
303	IFI-70001	BUTTONS BRACKET	\$ 16.06
304	IFE-05003-PS	START BUTTON GREEN	\$ 43.57
305	IFE-05003-PR	STOP BUTTON RED	\$ 43.57

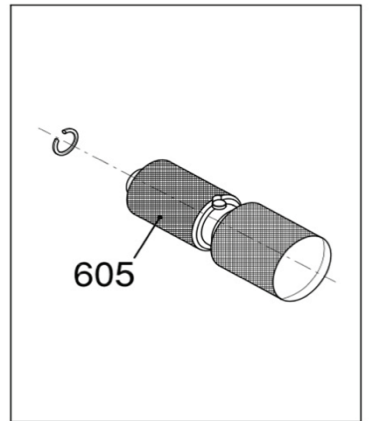
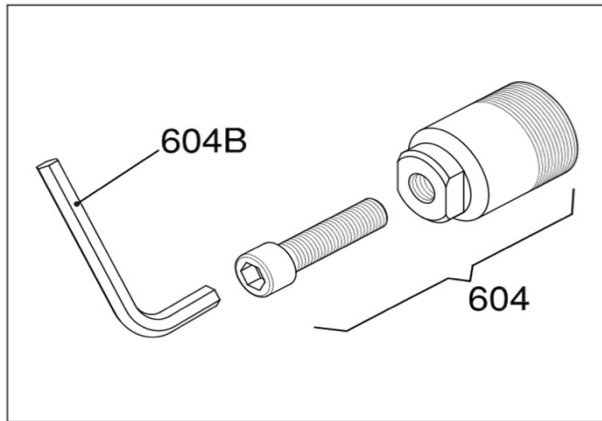
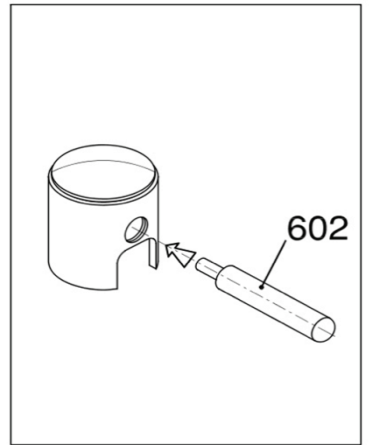
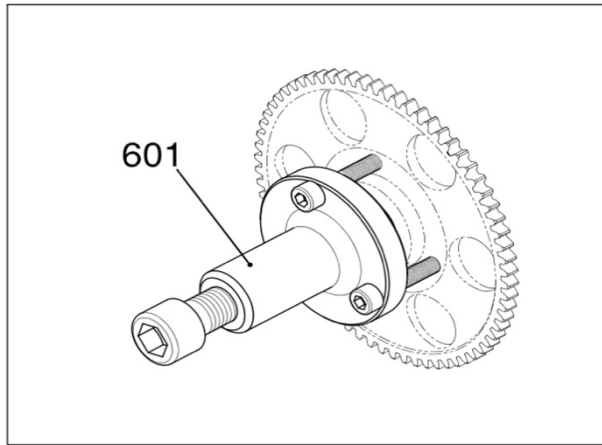
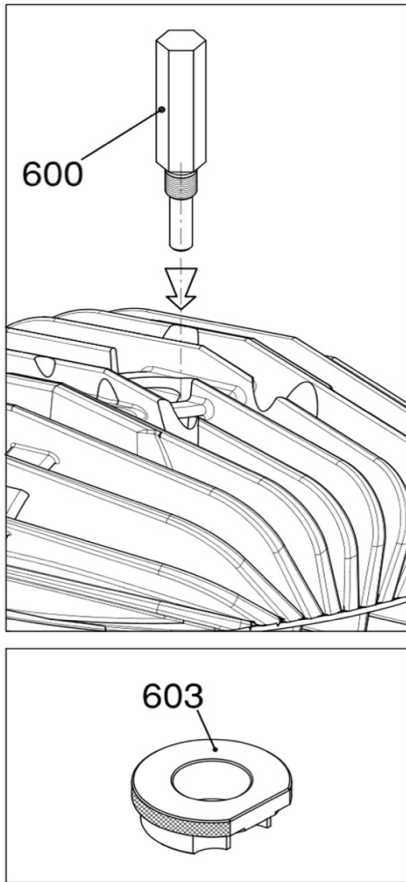

RJA-012

POS	PART #	DESCRIPTION	USA RETAIL
600	10271	PISTON STROKE LOCKER	\$ 38.12
601	ATT-039-C	STARTER GEAR PULLER	\$ 93.57
602	10200	PISTON PIN PUNCH 14mm 125cc	\$ 25.05
603	ATT-037	CRANK LOCKING TOOL	\$ 43.96
604	ATT-026	CLUTCH PULLER d.38 - KA100/ X30-2014 AND FORWARD	\$ 51.05
604B	10159	CLUTCH HUB PULLER WRENCH 12mm	\$ 23.00
605	10120	CIRCLIP ASSEMBLING TOOL 14mm	\$ 174.02

650
ATTREZZO MONTAGGIO ALBERO
ASSEMBLY CRANKSHAFT TOOL
OUTIL MONTAGE VILEBREQUIN

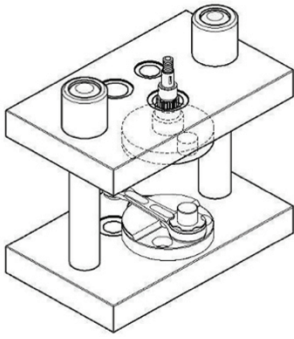

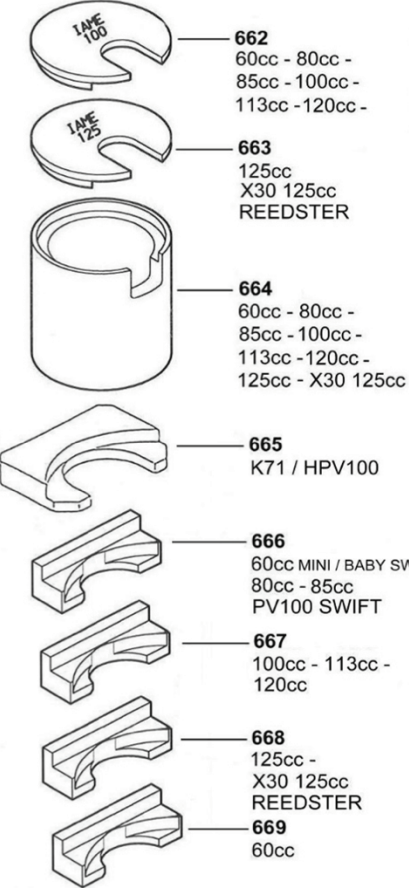

- 662**
60cc - 80cc -
85cc - 100cc -
113cc - 120cc -
- 663**
125cc
X30 125cc
REEDSTER
- 664**
60cc - 80cc -
85cc - 100cc -
113cc - 120cc -
125cc - X30 125cc
- 665**
K71 / HPV100
- 666**
60cc MINI / BABY SWIFT
80cc - 85cc
PV100 SWIFT
- 667**
100cc - 113cc -
120cc
- 668**
125cc -
X30 125cc
REEDSTER
- 669**
60cc

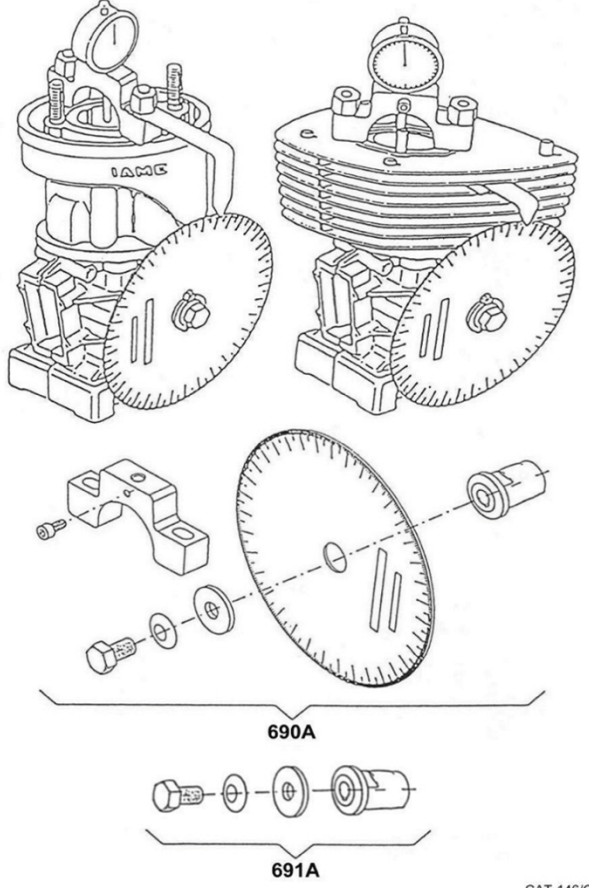

690A

691A

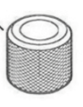
651  **X30 125cc REEDSTER**

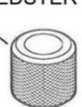
652  **X30 125cc REEDSTER**

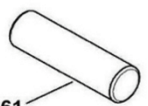
661 
60cc - 80cc -
85cc - 100cc -
113cc - 120cc -
125cc - X30 125cc
REEDSTER

CAT-146/C

POS	PART #	DESCRIPTION	USA RETAIL
650	10110A	CRANKSHAFT ASSY TOOL	\$ 1,956.82
652	10150A	CRANK-PIN BUSH 20mm	\$ 73.15
661	10107	CRANK-PIN PUSHER	\$ 11.66
663	10104A	CRANKSHAFT PLATE 125cc	\$ 100.61
664	10100	CRANKSH. DISASSY SUPPORT	\$ 167.09
668	10106	CRANKSHAFT INSERT 125cc-SUP	\$ 54.29
690A	10820A	TIMING CHECK DISC TaG/REEDSTER	\$ 130.03
691A	10828-C	TIMING CHECK DISC ADAPTER M10	\$ 53.38

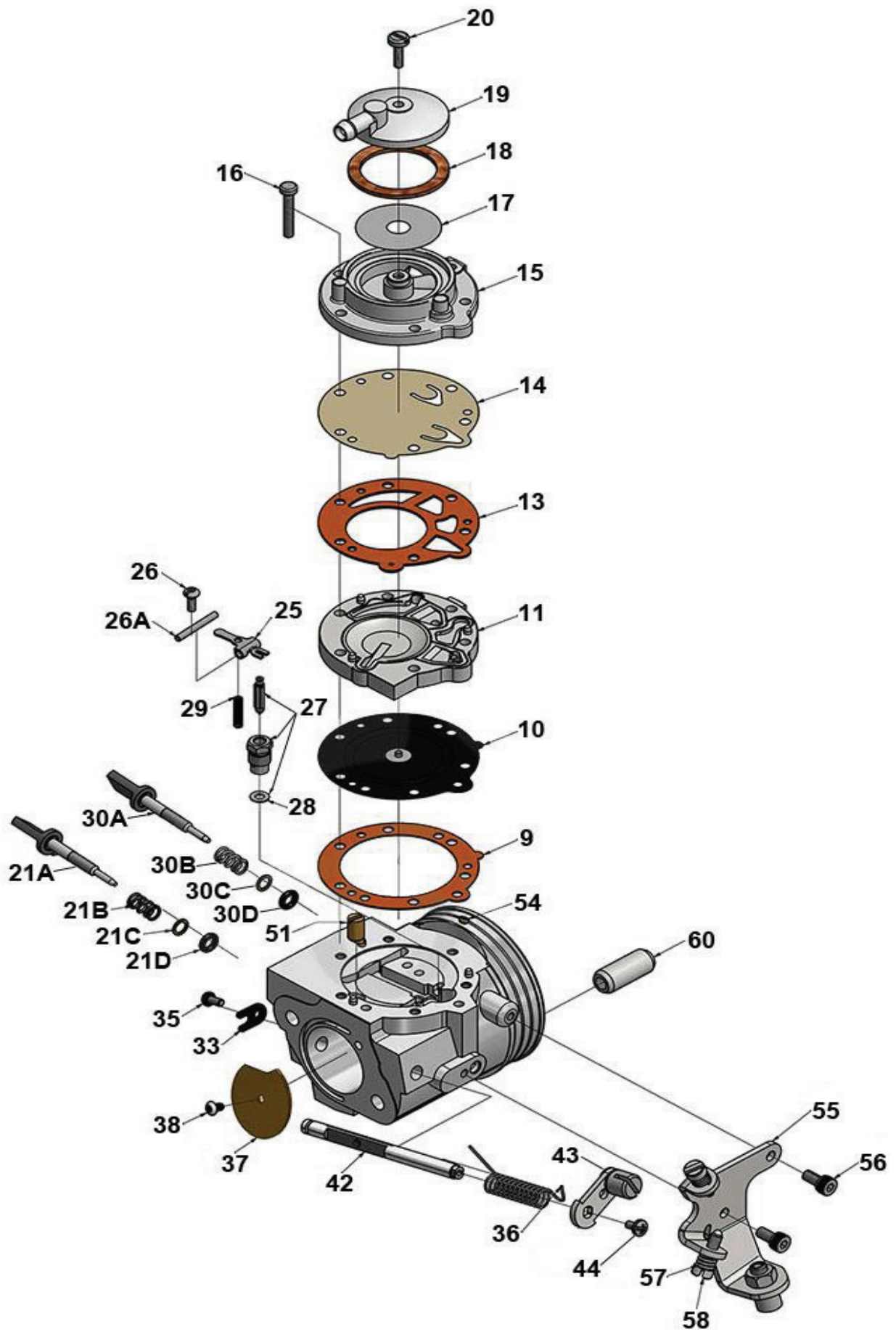

TILLOTSON HW-33A CARB			KA100
POS	PART #	DESCRIPTION	USA RETAIL
9	TI-16-B406	DIAPHRAGM GASKET	
10	TI-237-600X	DIAPHRAGM	\$ 4.91
11	TI-91A-275	DIAPHRAGM COVER	\$ 7.07
13	TI-16-B407X	FUEL PUMP GASKET	\$ 35.77
14	TI-237-162X	FUEL PUMP DIAPHRAGM	\$ 56.94
15	TI-141-89T	FUEL PUMP BODY	\$ 9.67
16	TI-15C-51X	FUEL PUMP BODY SCREW	\$ 9.10
17	TI-95-170X	FUEL STRAINER SCREEN	\$ 9.20
18	TI-16-B205X	FUEL STRAINER COVER GASKET	\$ 6.60
19	TI-91-A251	FUEL STRAINER COVER	\$ 3.04
20	TI-15-B313X	FUEL STRAINER COVER RETAINING SCREW	\$ 7.10
21A	TI-43-1029	IDLE MIXTURE SCREW	\$ 10.16
21B	TI-24-B449X	IDLE MIXTURE SCREW SPRING	\$ 5.90
21C	TI-78A-256X	IDLE MIXTURE SCREW WASHER	\$ 7.60
21D	TI-44-361X	IDLE MIXTURE SCREW PACKING	\$ 10.40
25	TI-155A-27X	INLET CONTROL LEVER	\$ 9.60
26	TI-15-B329X	FULCRUM LEVER SCREW	\$ 6.90
26A	TI-32-79X	FULCRUM LEVER PIN	\$ 5.90
27	TI-233-721P	INLET NEEDLE & SEAT SET	\$ 15.45
28	TI-16-B199X	INLET SEAT GASKET	\$ 5.30
29	TI-24-B323X	INLET TENSION SPRING 26G	\$ 15.80
29	TI-24-C296X	INLET TENSION SPRING 31G	\$ 31.72
29	TI-24-B299X	INLET TENSION SPRING 37G	\$ 12.59
29	TI-24-C298X	INLET TENSION SPRING 42G	\$ 31.48
29	TI-24-C297X	INLET TENSION SPRING 46G	\$ 30.75
30A	TI-43-1030	HIGH SPEED MIXTURE SCREW	\$ 10.16
30B	TI-24B-449X	HIGH SPEED MIXTURE SCREW SPRING	\$ 5.90
30C	TI-78-A256X	HIGH SPEED MIXTURE SCREW WASHER	\$ 7.60
30D	TI-44-361X	HIGH SPEED MIXTURE SCREW PACKING	\$ 10.40
33	TI-29-224X	THROTTLE SHAFT CLIP	\$ 9.80
35	TI-15-C19X	THROTTLE SHAFT CLIP RETAINING SCREW	\$ 8.70
36	TI-24-B381X	THROTTLE RETURN SPRING	\$ 9.10
37	TI-14-A118	THROTTLE SHUTTER	\$ 19.11
38	TI-15-C20X	THROTTLE SHUTTER SCREW	\$ 8.70
42	TI-13-B216	THROTTLE SHAFT	\$ 15.50
43	TI-12-1220	THROTTLE LEVER ASSEMBLY	\$ 17.20
44	TI-15-C52X	THROTTLE LEVER RETAINING SCREW	\$ 12.20
51	TI-363-318	IDLE NOZZLE	\$ 18.98
54	TI-80-160X	MAIN PLUG	\$ 18.05
55	TI-136-562	CABLE BRACKET	\$ 20.18
56	TI-15-C67X	CABLE BRACKET RETAINING SCREW	\$ 8.70
57	TI-15-C9X	LIMITER SCREW	\$ 22.10
58	TI-24-B131X	LIMITER SPRING	\$ 6.83
60	TI-81-377	CARBURETTOR MOUNTING NUT	\$ 3.00
	24C-334X	AUXILIARY CABLE RETURN SPRING	\$ 42.45
	TI-RK-6HW	REPAIR KIT	\$ 32.95
	TI-DG-3HW	DIAPHRAGM & GASKET	\$ 14.95
	TI-233-721P	INLET NEEDLE & SEAT SET	\$ 15.45