
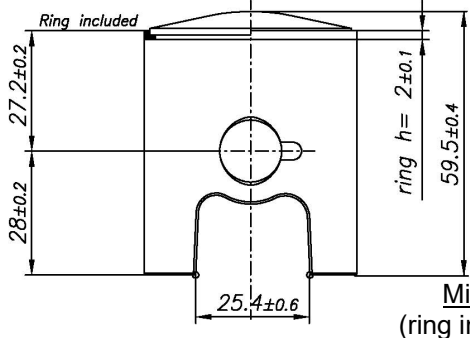
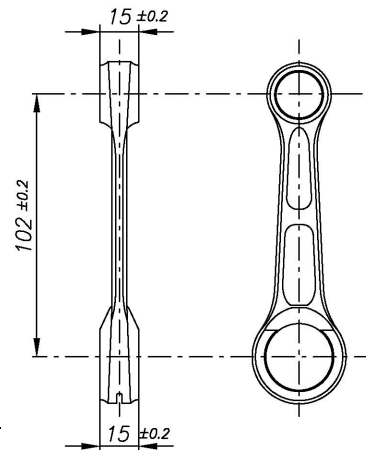


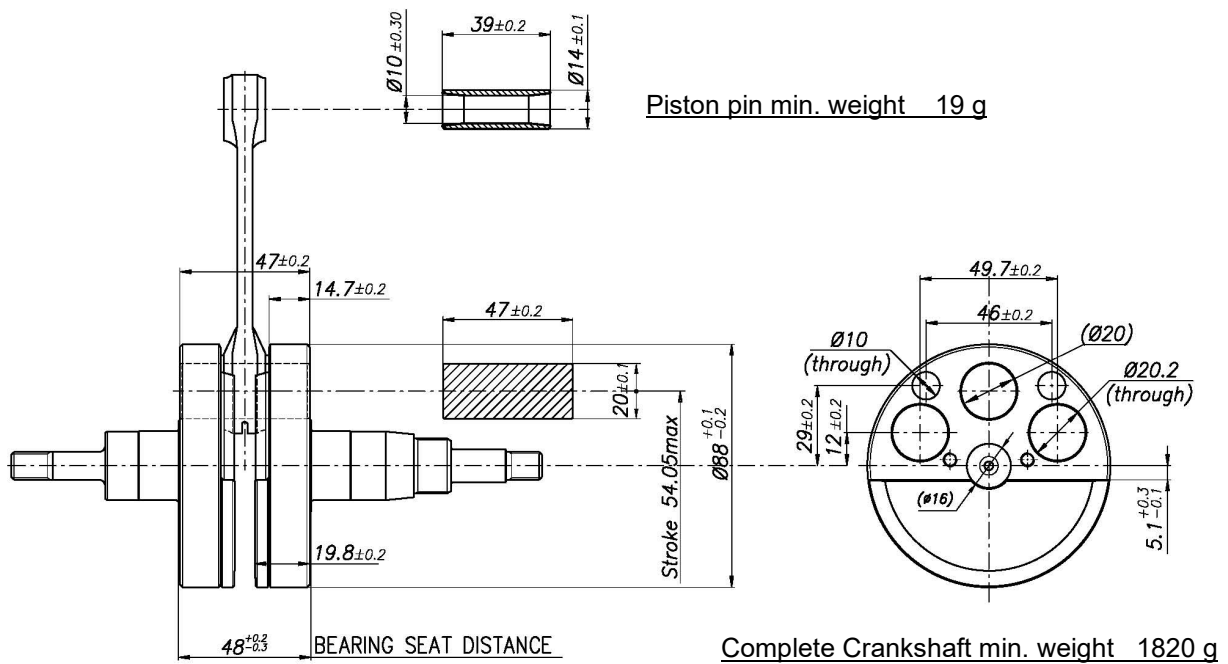
# 100cc REEDJET USA - TAG

## FEATURES

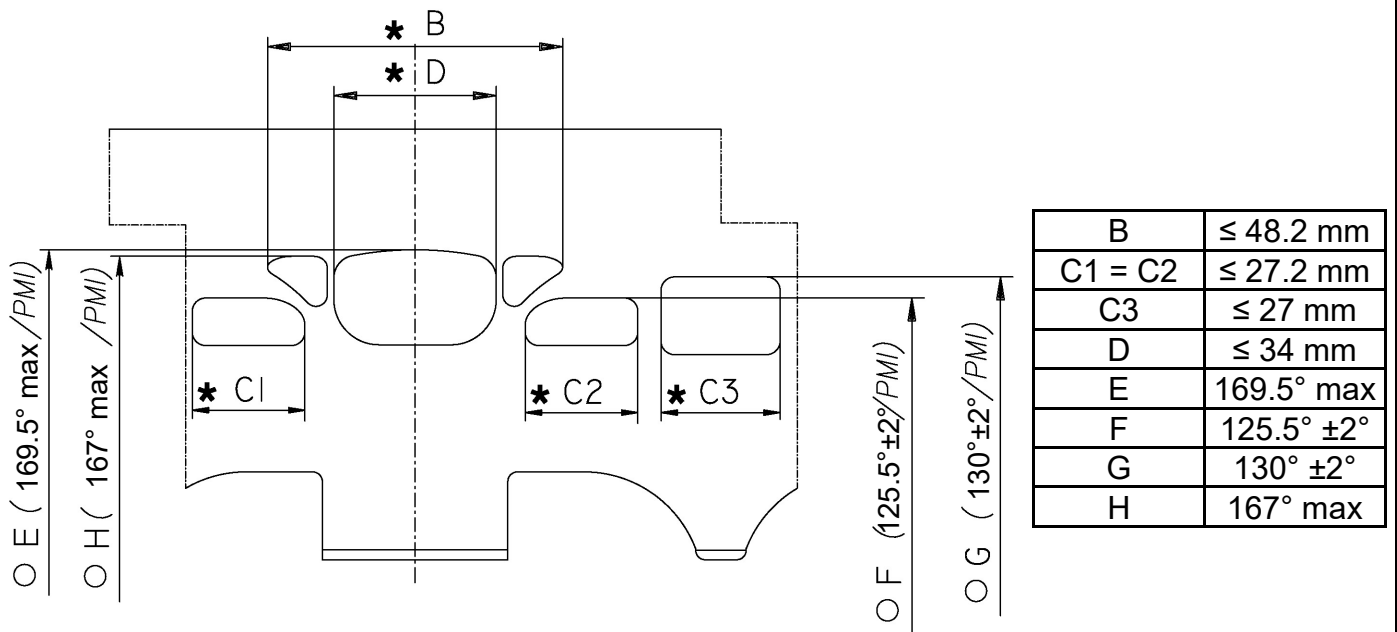
		Cylinder Volume	100 cm <sup>3</sup> max
		Bore	48.20 mm
		Max. bore	48.55 mm
		Stroke	54.05 mm max
		Cooling system	Air
		Inlet system	Reed valve
		Number of carbs	1
Tillotson Carburettor	HW-33A Ø24mm	Cylinder / crankcase transfers n°	3 / 3
Number of piston rings	1	Transfers / Exhaust ports number	3 / 3
Big end conr. ball-bearing diam.	20x26x15	Combustion chamber shape	Spherical
Crankshaft ball-bearing diam.	25x52x15	Selettra ignition (adjustable)	Analogue 2 Poles
Small end conr. ball-bearing diam.	14x18x18	Distance between Conrod centres	102 mm

DESCRIPTION OF THE MATERIAL		PISTON	
Conrod material	Steel		
Crankshaft material	Steel		
Head material	Aluminium		
Cylinder material	Aluminium		
Liner material	Cast Iron		DISTANCE BETWEEN CONROD CENTERS
Crankcase material	Aluminium		
Piston material	Aluminium		
Piston rings material	Cast Iron		
Exhaust muffler material	Sheet-steel		
Ball-bearings	6205 type		

### CRANKSHAFT



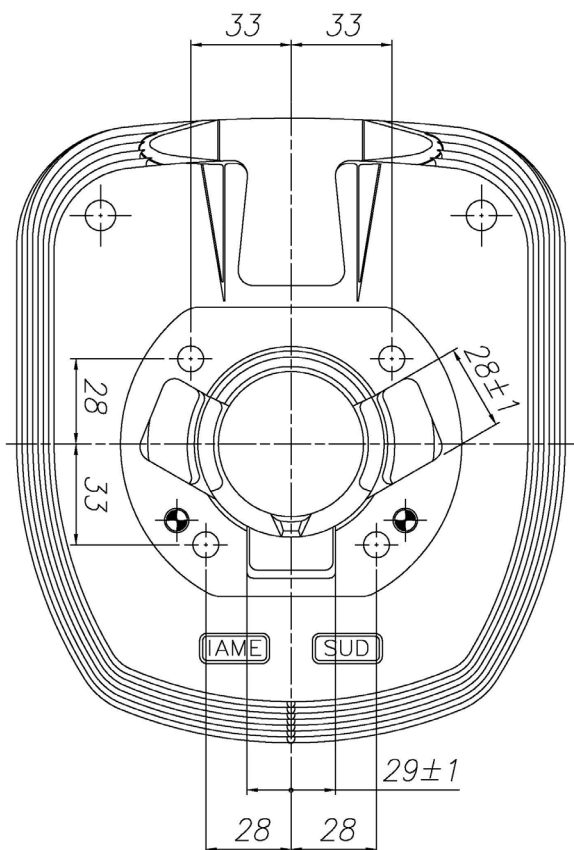
## CYLINDER DEVELOPMENT



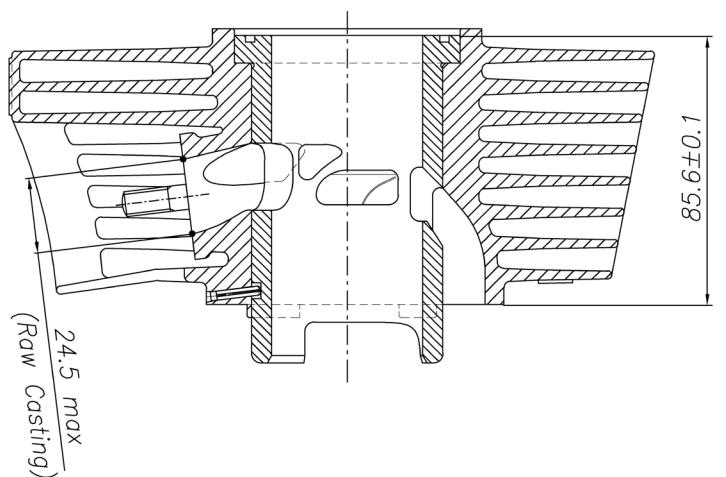
**\* CHORDAL READING**

$\bigcirc$  ANGULAR READING BY INSERTING A 0.2x5 mm GAUGE

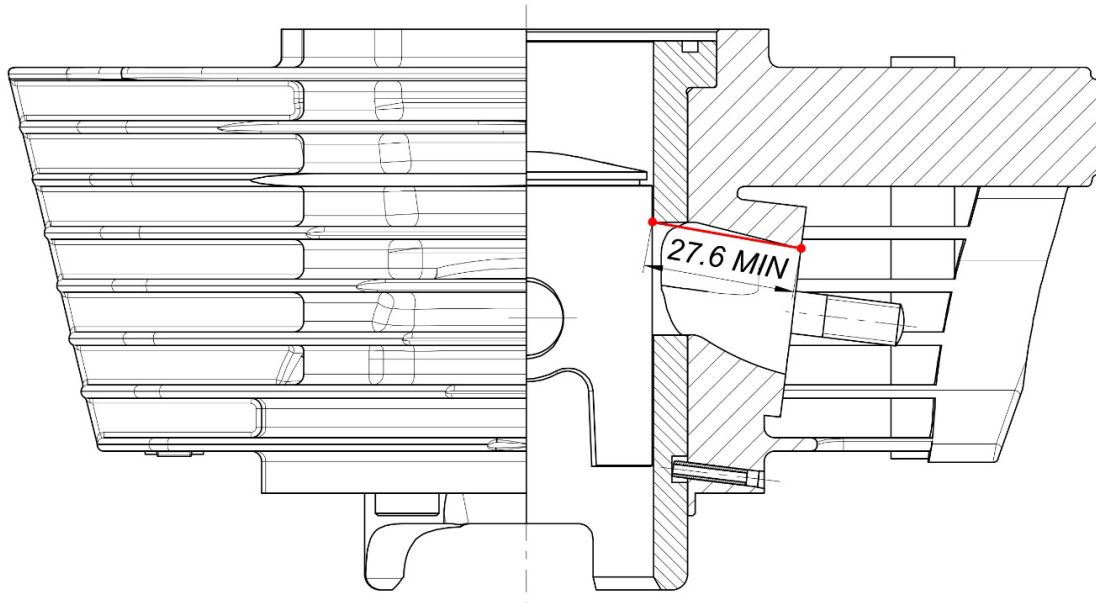
### CYLINDER BASE VIEW



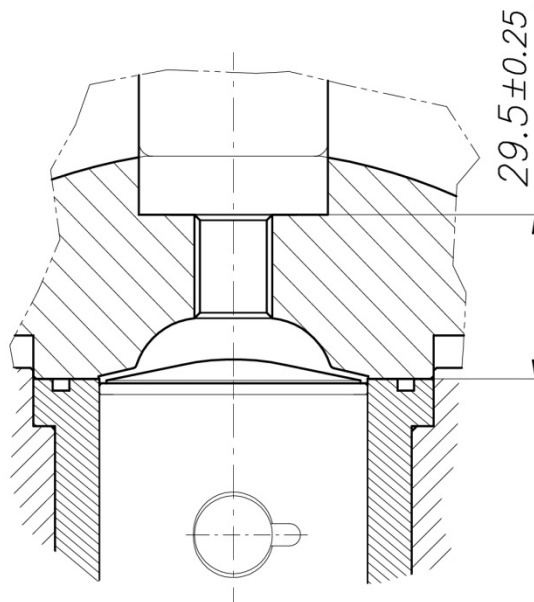
### CYLINDER CROSS SECTION VIEW



DISTANCE FROM EXHAUST FLANGE TO PISTON



COMBUSTION CHAMBER VIEW

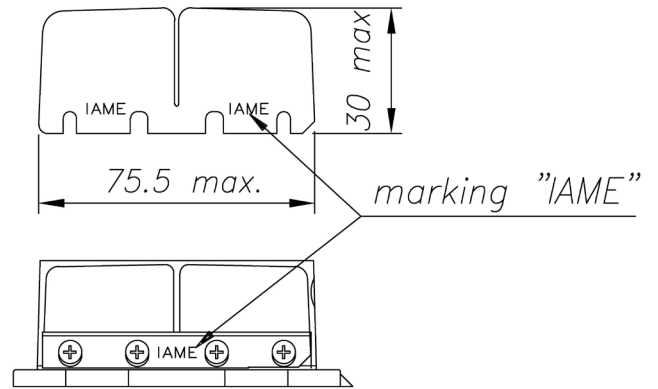
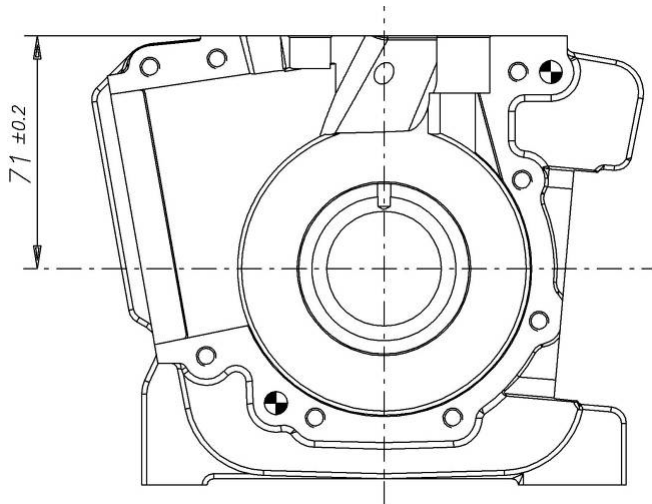


**SQUISH MIN. = 0.0413" (1.05 mm)**  
*(measured with 0.0625" (1/16") / Ø1.58mm solder)*



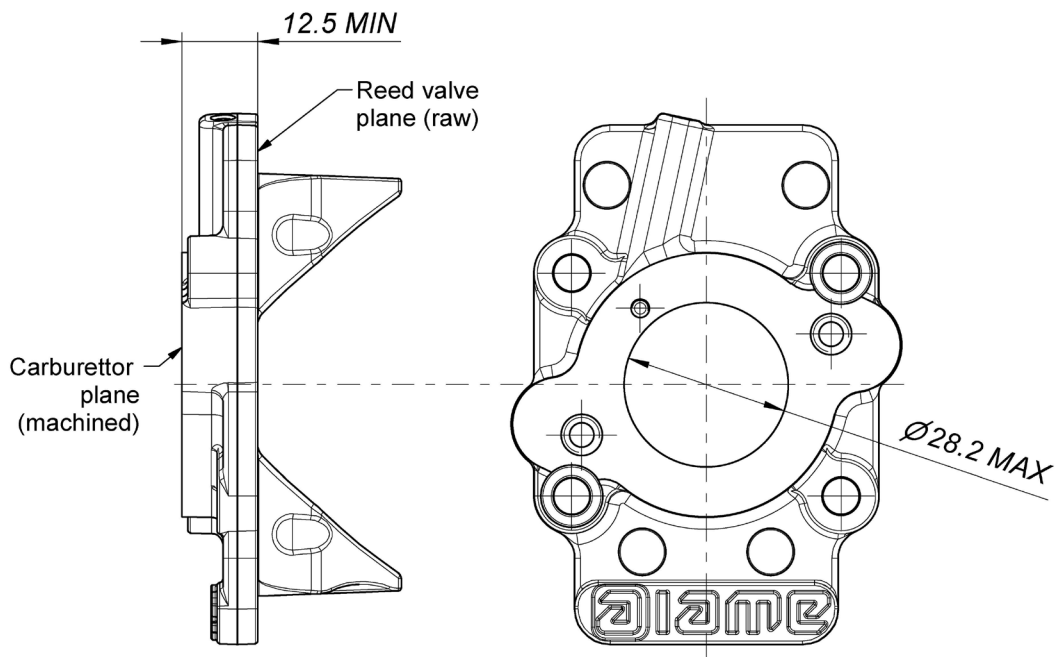
CRANKCASE INSIDE VIEW

REEDS DIMENSIONS



**Genuine IAME fiber glass reeds min. thickness 0.30mm**

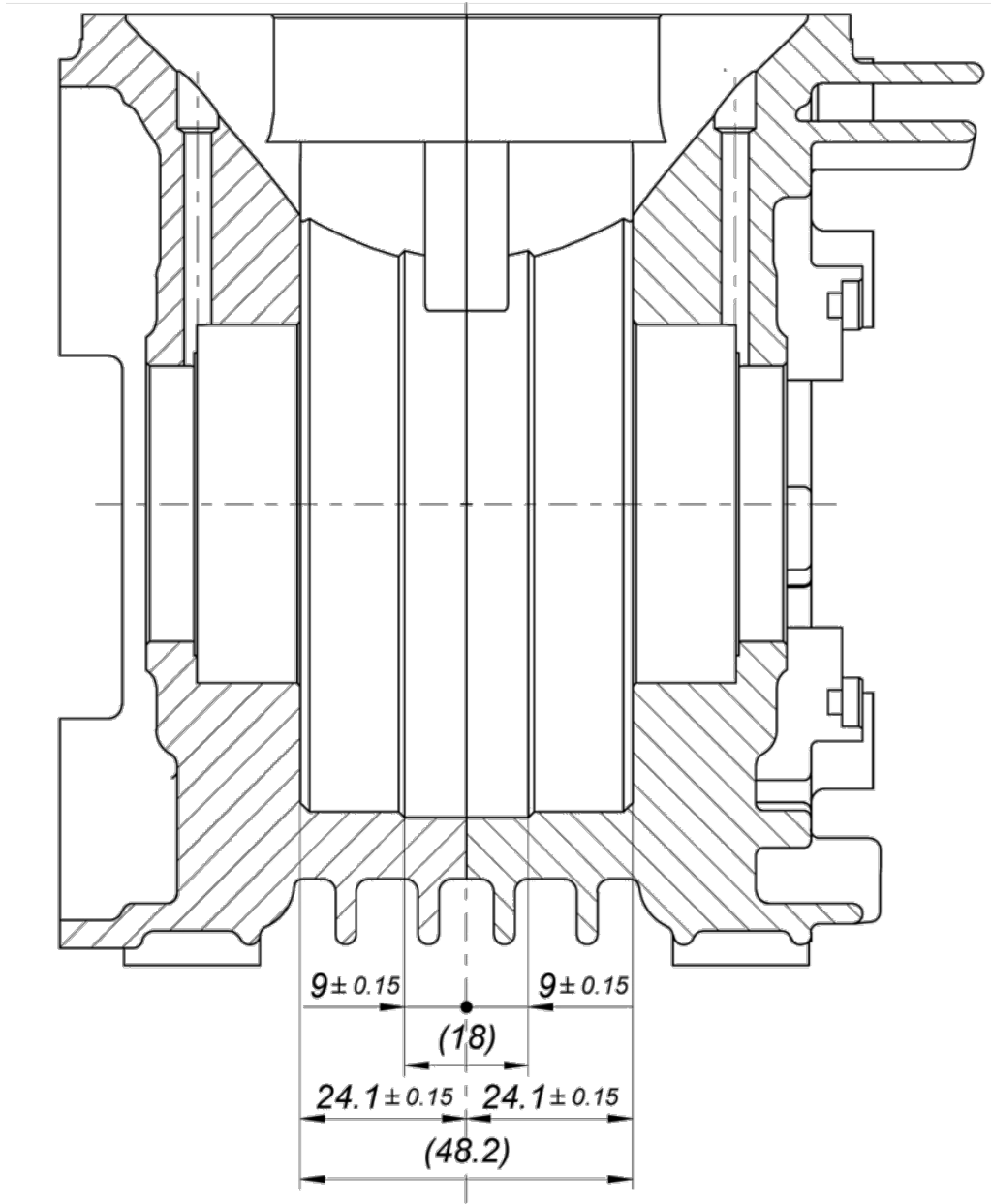
INLET CONVEYOR DIMENSIONS



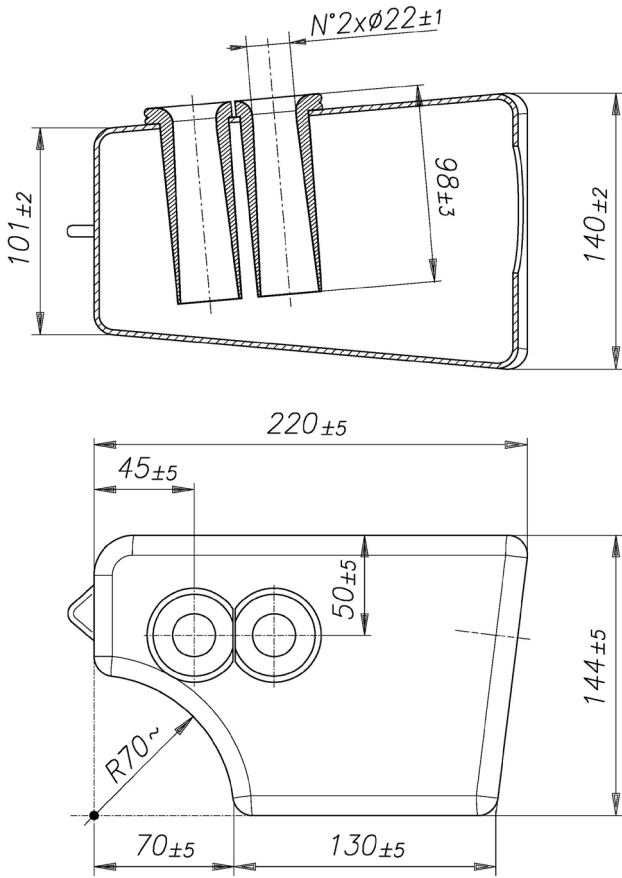
# CRANKCASE WIDTH DIMENSIONS

DRIVE SIDE

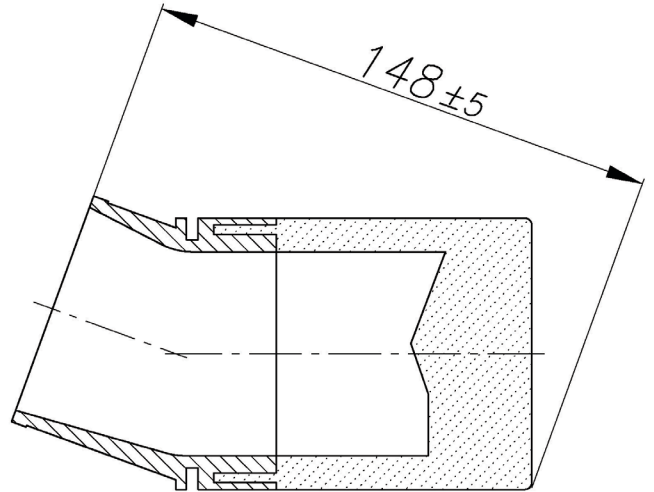
IGNITION SIDE



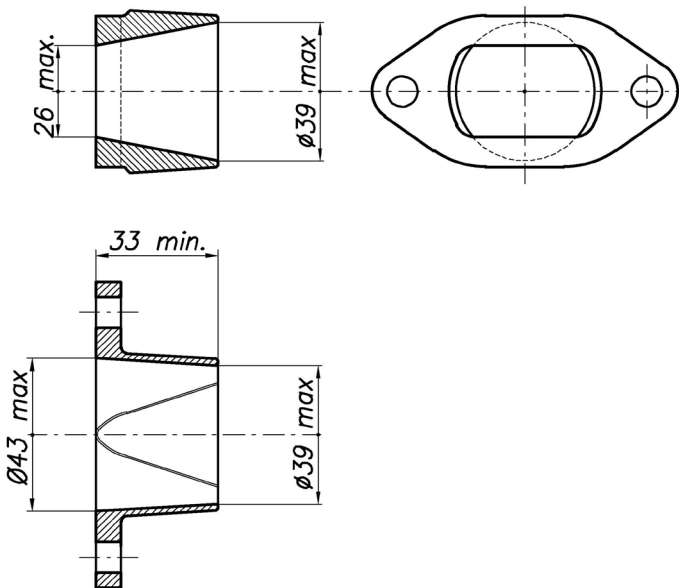
INLET SILENCER



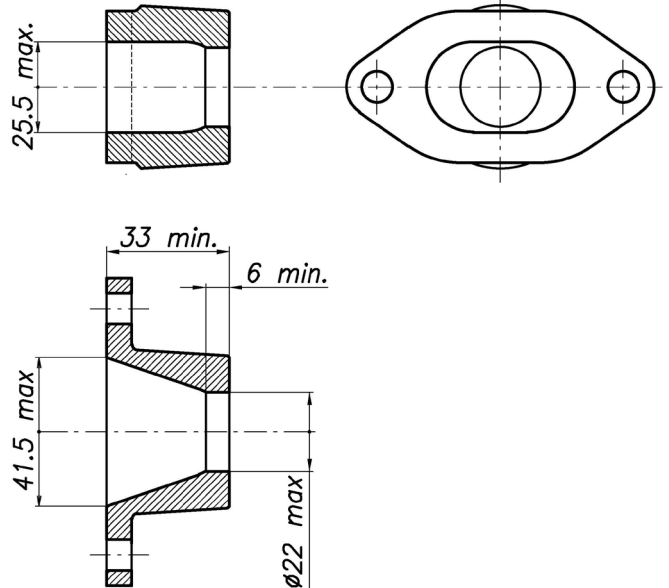
SPONGE FILTER INLET SILENCER



EXHAUST MANIFOLD



EXHAUST MANIFOLD RESTRICTED



INLET SILENCER TUBES NEW TYPE

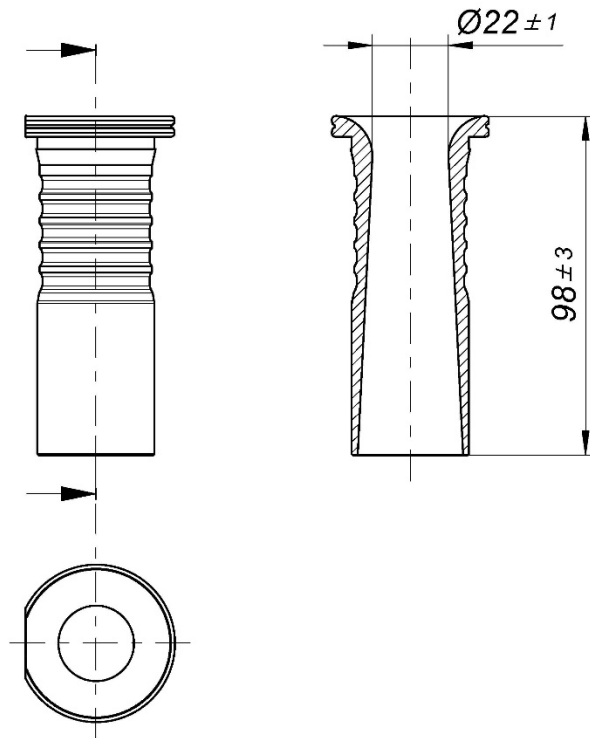
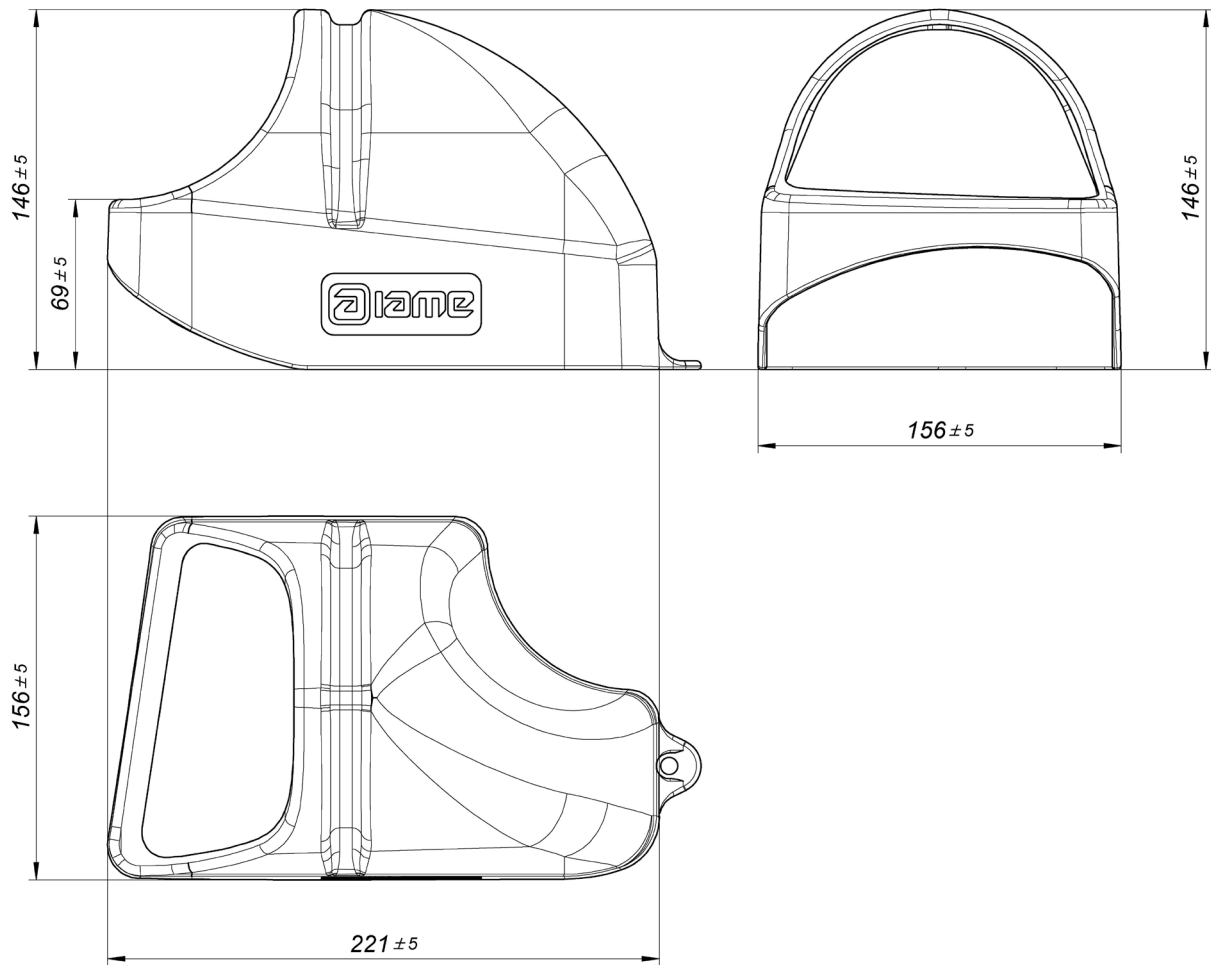


PHOTO IDENTIFICATION OF PERMISSIBLE INLET SILENCER TUBES



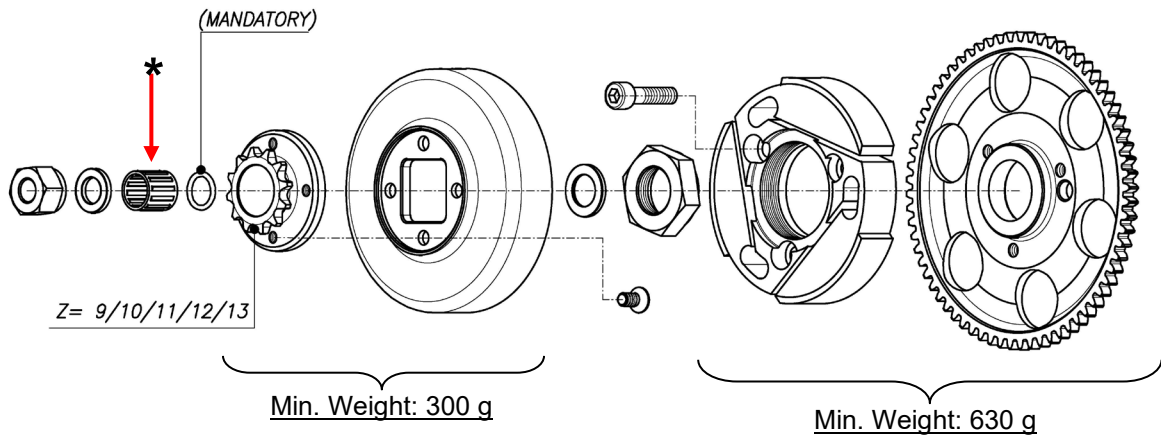
## RAIN COVER INLET SILENCER – DRAWING



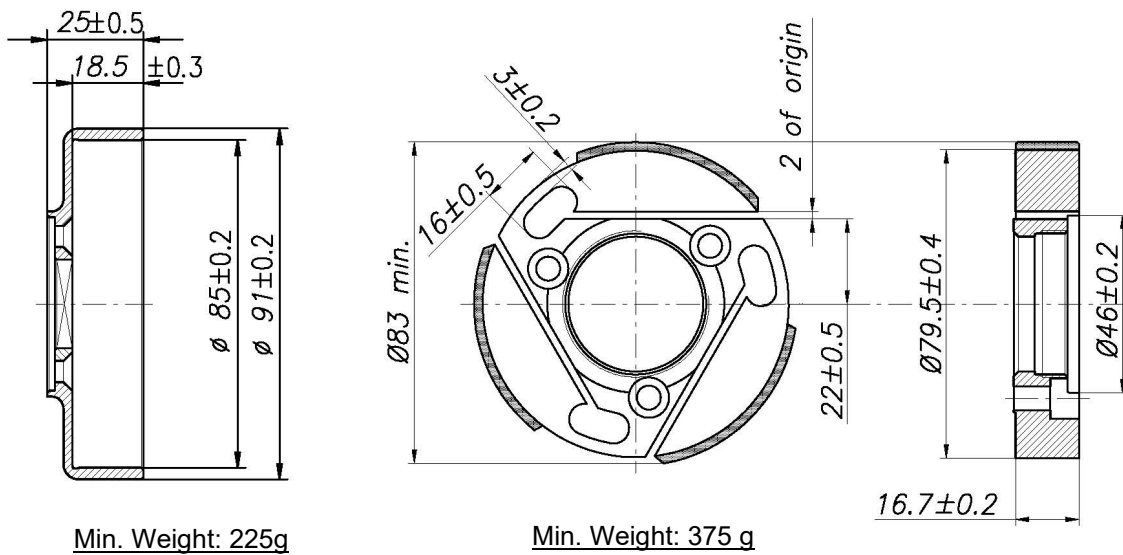
## PHOTO IDENTIFICATION OF RAIN COVER INLET SILENCER



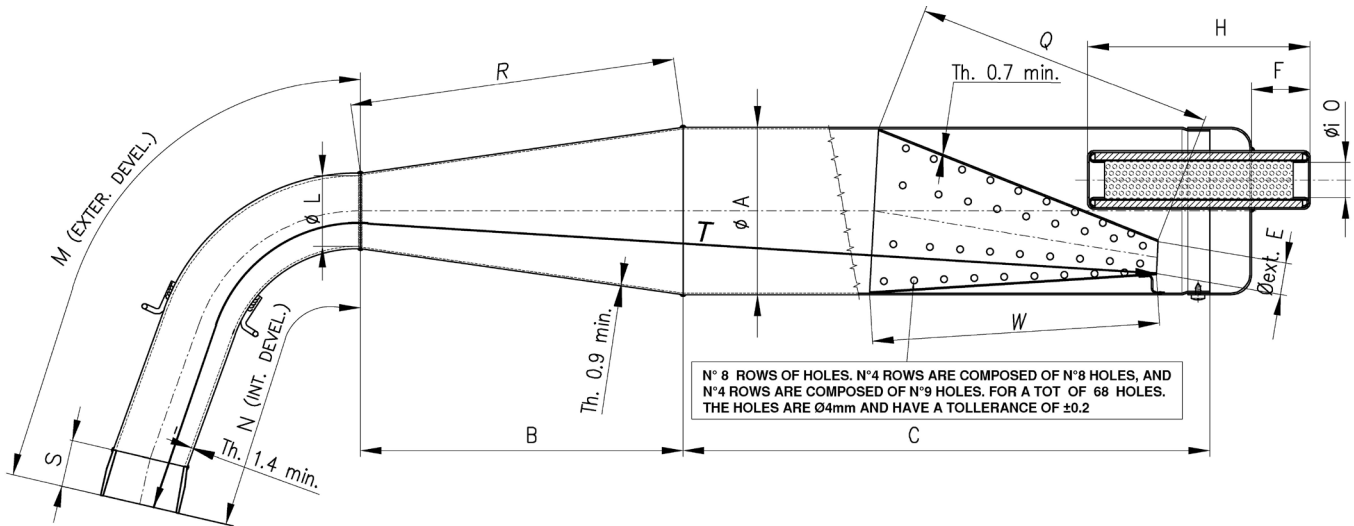
## DESCRIPTION OF THE CLUTCH



\* When using the Z9, the roller cage is replaced by a bronze bushing, pressed into the sprocket



**EXHAUST VIEW AND DIMENSIONS**  
(valid also for alternative exhaust type)



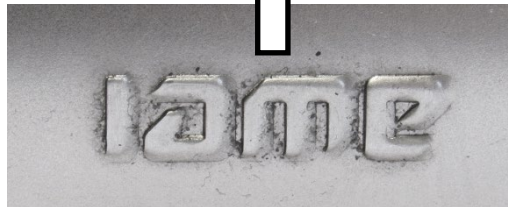
Min. Weight: 1.905 g

<b>ØA:</b> <u>100 ±1</u> Øext.	<b>C:</b> <u>315 ±3</u>	<b>H:</b> <u>132 ±3</u>	<b>ØiO:</b> <u>21 ±1</u> Øint.	<b>S:</b> <u>29 ±1.5</u>
<b>ØL:</b> <u>45 ±1</u> Øext.	<b>ØE:</b> <u>23.5 ±2</u> Øext.	<b>M:</b> <u>270 ±3</u> ext.	<b>R:</b> <u>194.5 ±3</u>	<b>T:</b> <u>692 ±3</u>
<b>B:</b> <u>193 ±3</u>	<b>F:</b> <u>36 ±2</u>	<b>N:</b> <u>210 ±3</u> ext.	<b>Q:</b> <u>182 ±3</u>	<b>W:</b> <u>170 ±3</u>

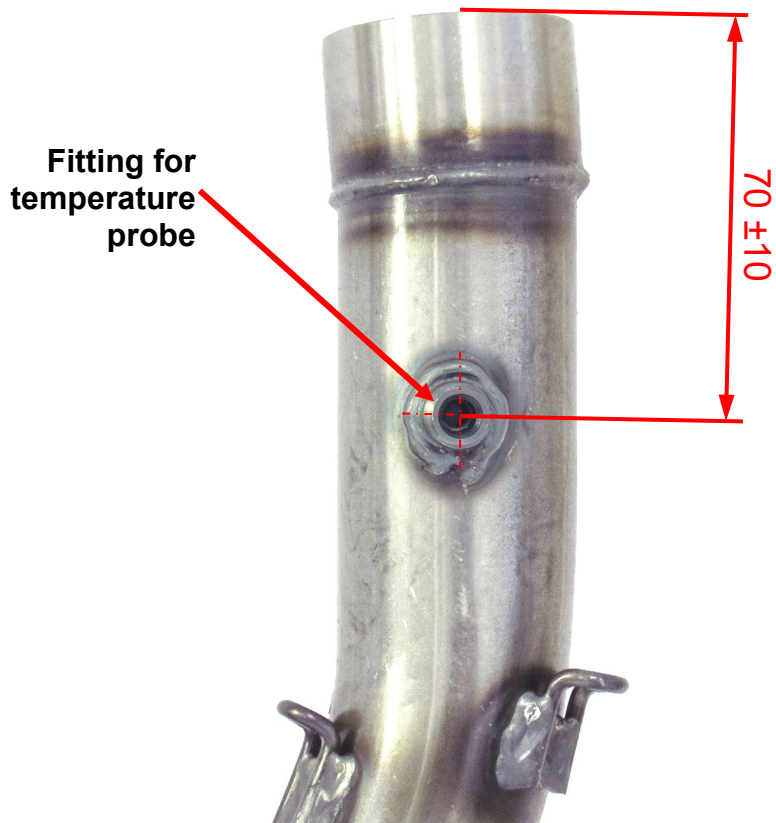
**ATTENTION:**

The dimensions “**M**”, “**N**” and “**T**” must be taken by steel tape measure 6mm wide.  
The dimensions “**Q**” and “**W**” must be taken by steel tape measure 12mm wide.

ALTERNATIVE EXHAUST



MARKING





# WIRING DIAGRAM

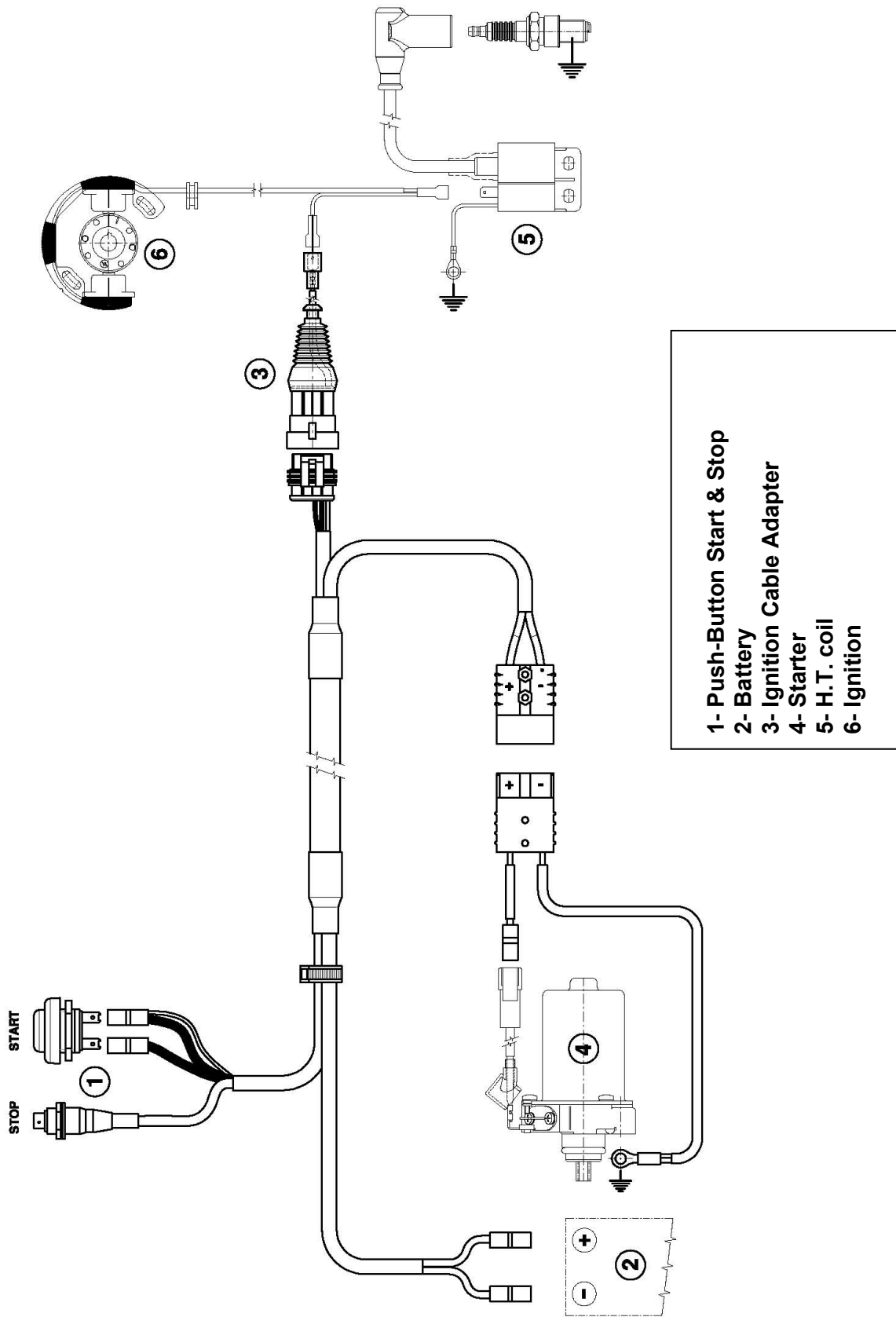
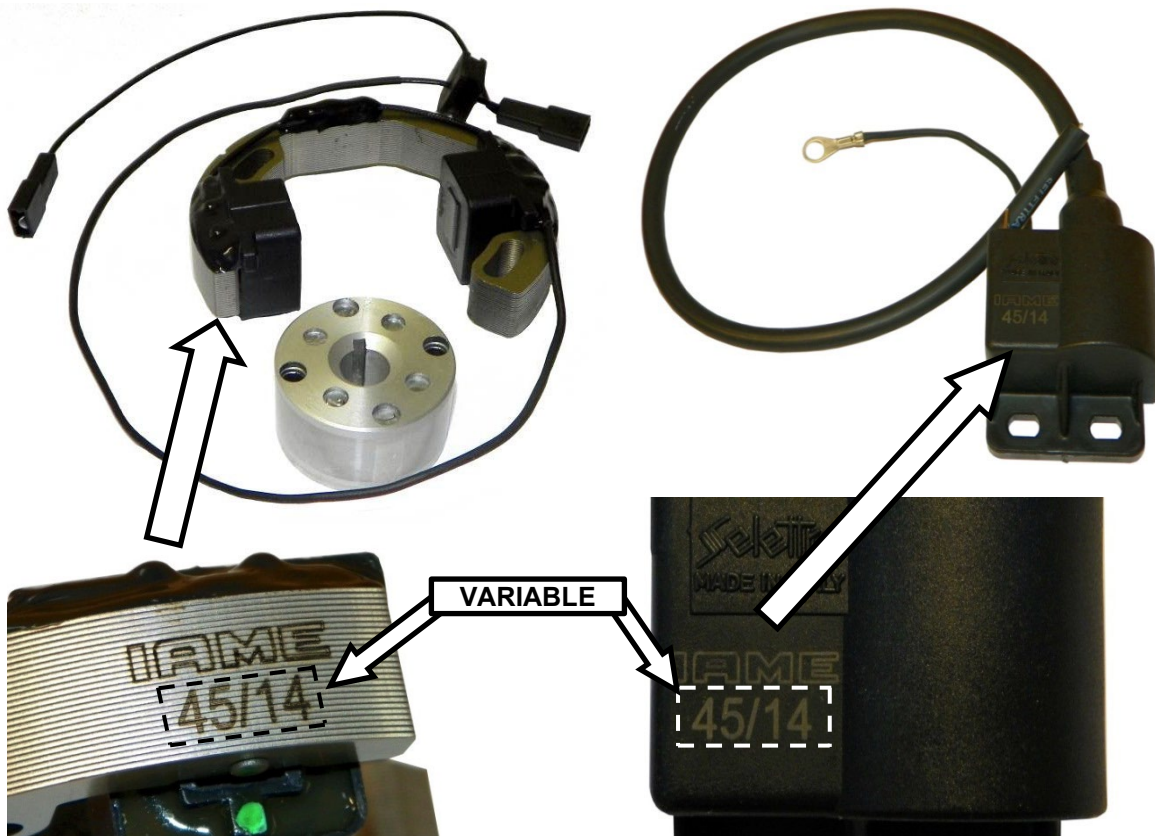


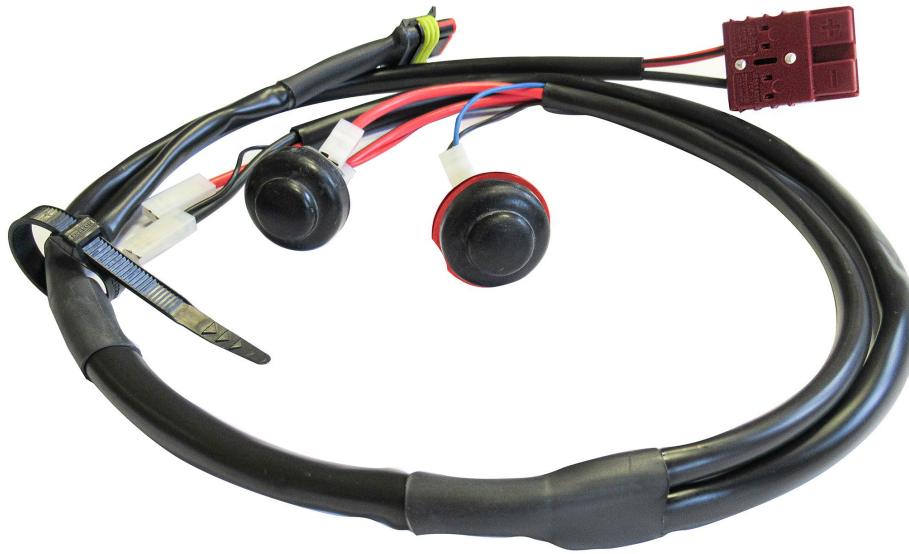
PHOTO COMPLETE WIRING



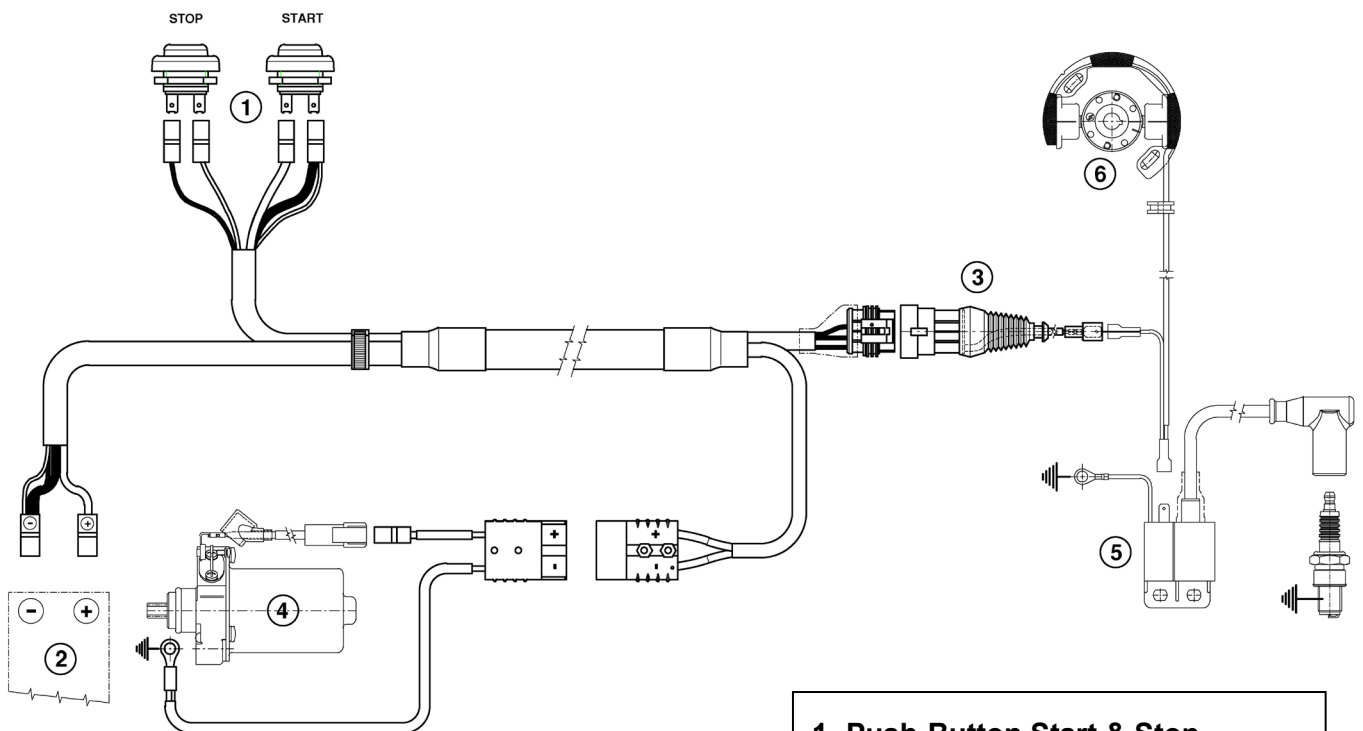
PHOTO OF IGNITION / PHOTO OF H.T. COIL (SELETTRA ANALOGUE 2 POLES)



## ALTERNATIVE WIRING LOOM



## ALTERNATIVE WIRING LOOM DIAGRAM

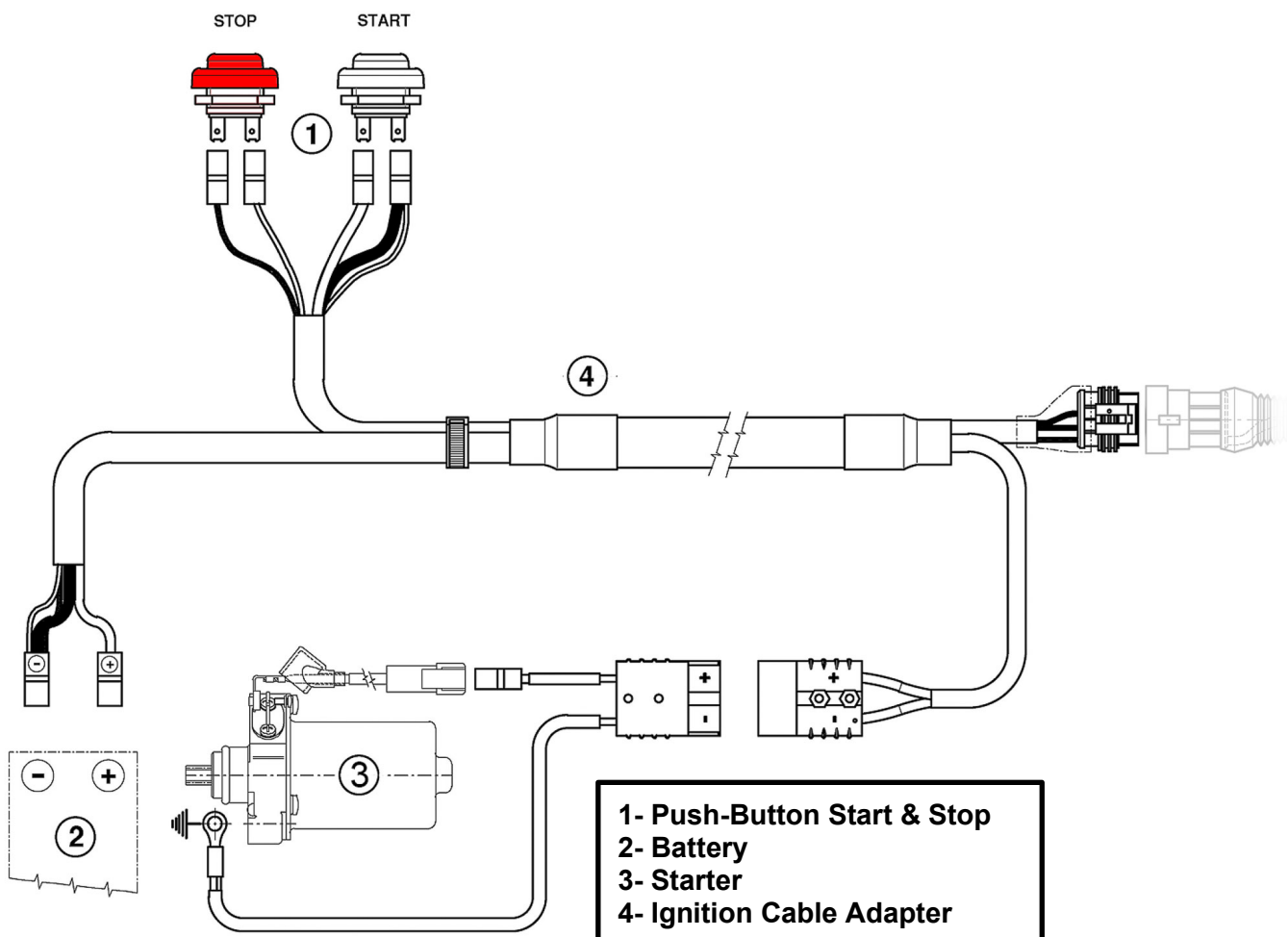


- 1- Push-Button Start & Stop
- 2- Battery
- 3- Ignition Cable Adapter
- 4- Starter
- 5- H.T. coil
- 6- Ignition

## ALTERNATIVE WIRING LOOM

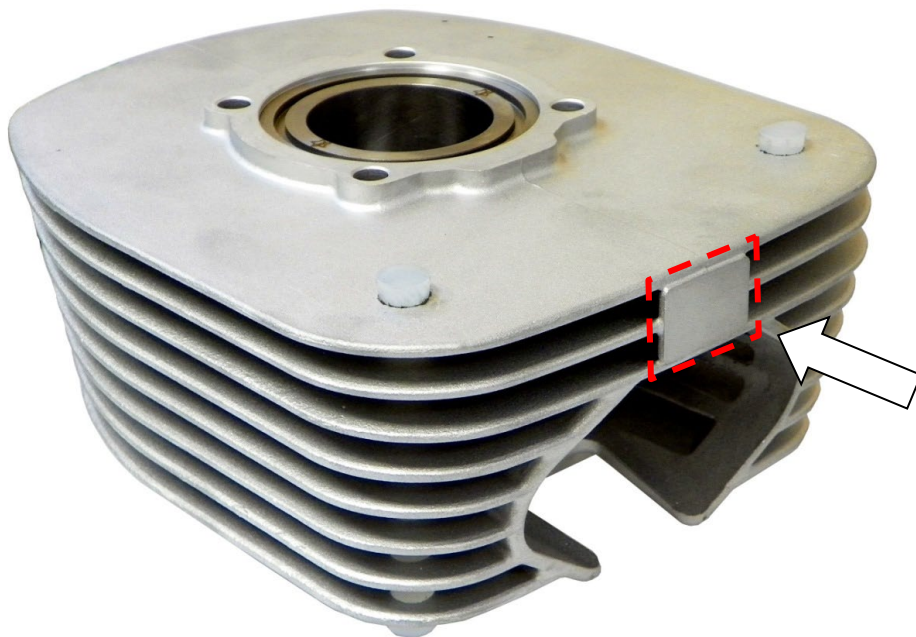
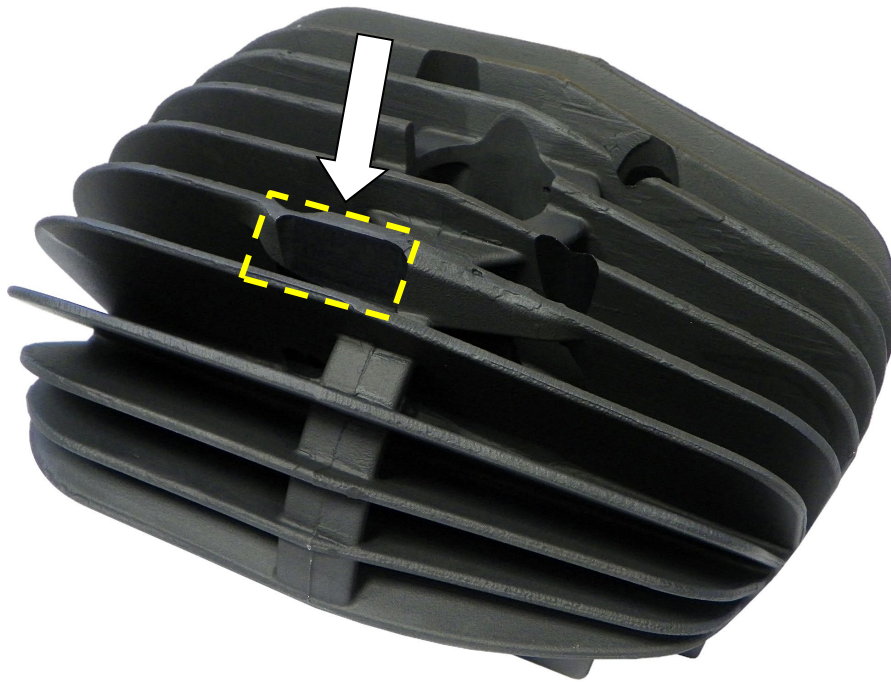


## ALTERNATIVE WIRING LOOM DIAGRAM





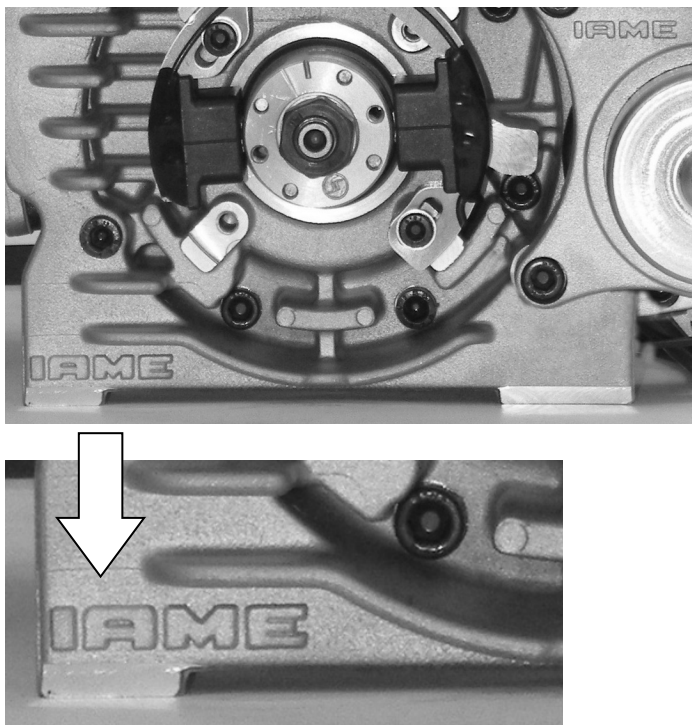
## STICKER APPLICATION AREA



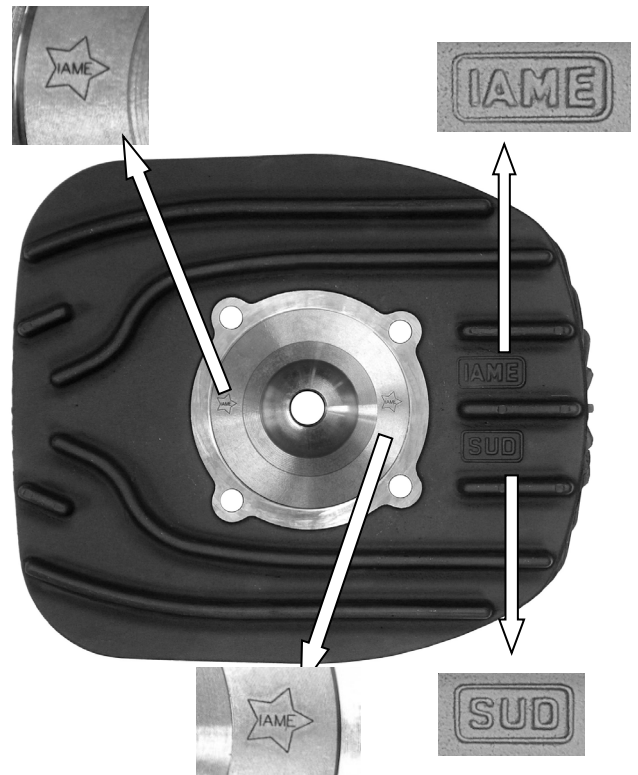
## CYLINDER IDENTIFICATION MARKING



## CRANKCASE IDENTIFICATION MARKING



## HEAD IDENTIFICATION MARKING

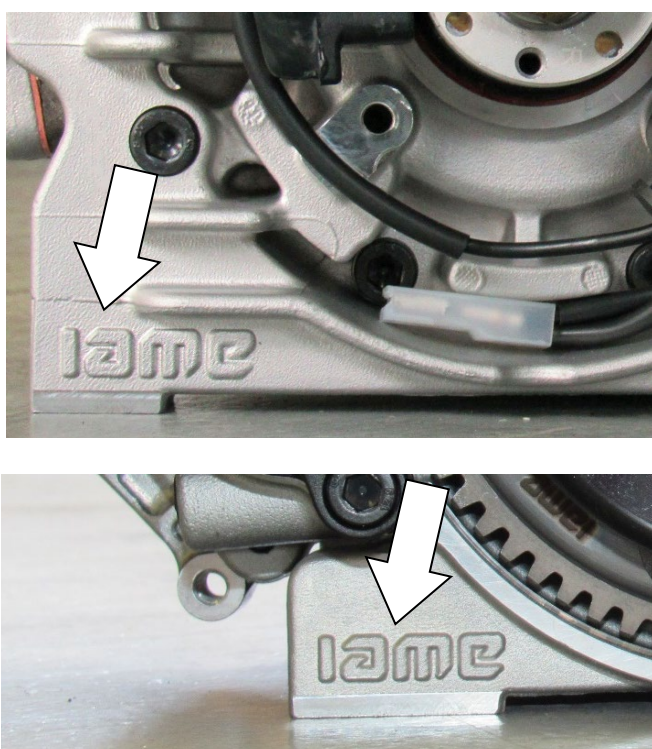




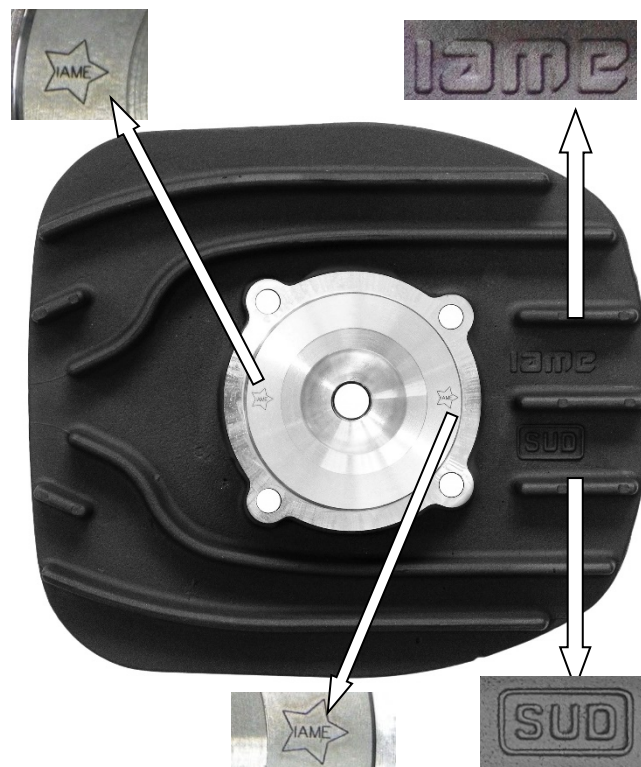
## ALTERNATIVE CYLINDER IDENTIFICATION MARKING



## ALTERNATIVE CRANKCASE IDENTIFICATION MARKING



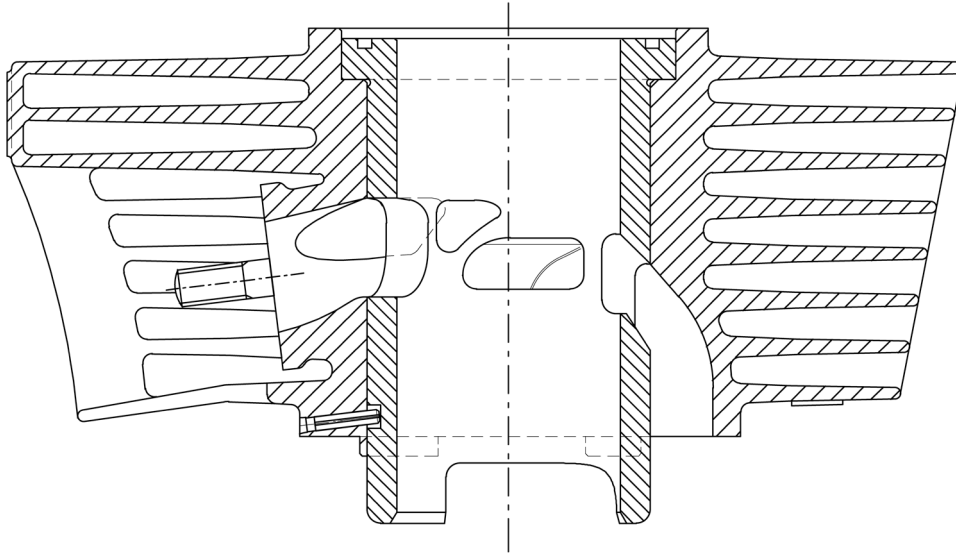
## ALTERNATIVE CYLINDER HEAD IDENTIFICATION MARKING



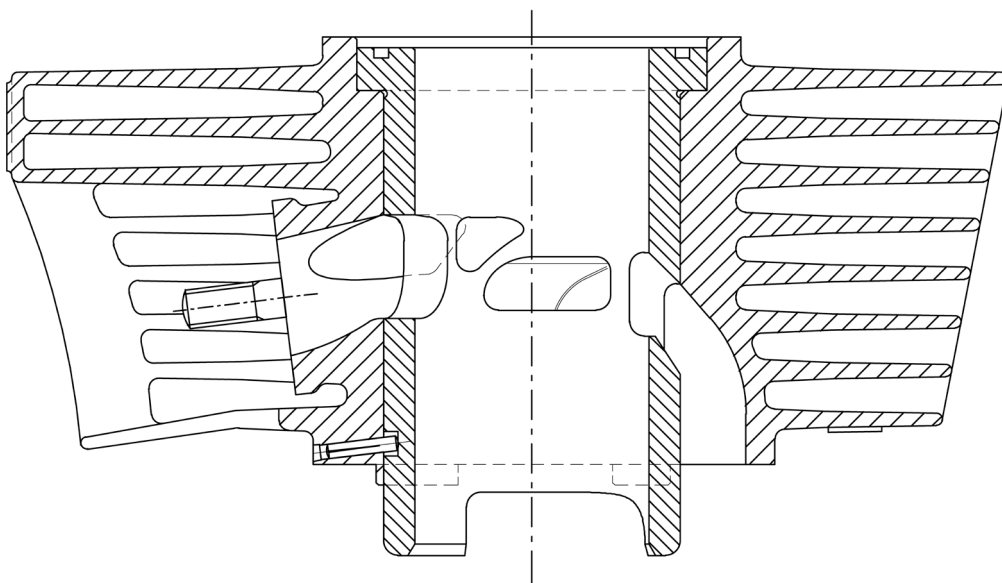
**FROM 2025 ON**

**CYLINDER IDENTIFICATION – ALTERNATIVE CYLINDER LINER LOCK PIN**

**CURRENT PIN (SPRING PIN)**



**ALTERNATIVE PIN (GROOVED PIN)**

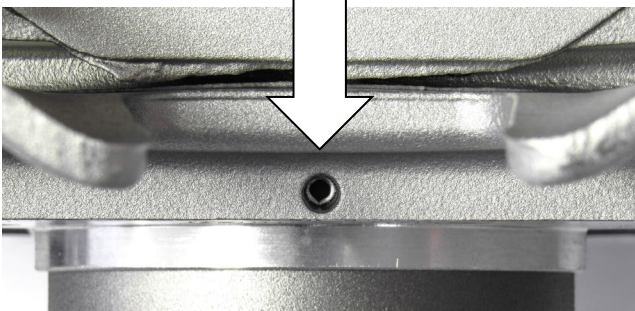




**FROM 2025 ON**

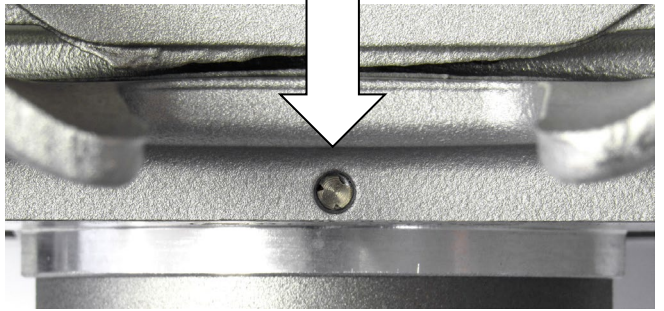
CYLINDER IDENTIFICATION – ALTERNATIVE CYLINDER LINER LOCK PIN

CURRENT PIN



SPRING PIN

ALTERNATIVE PIN



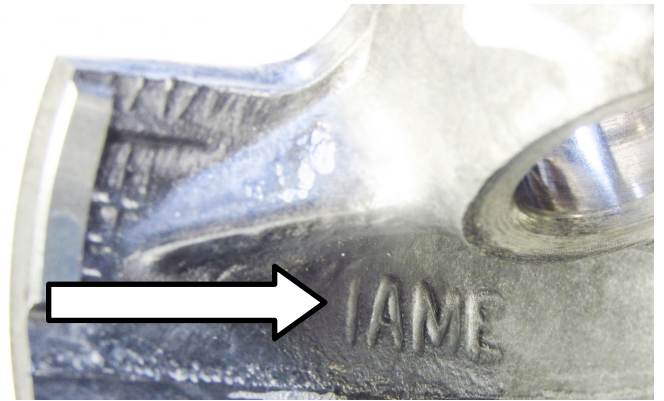
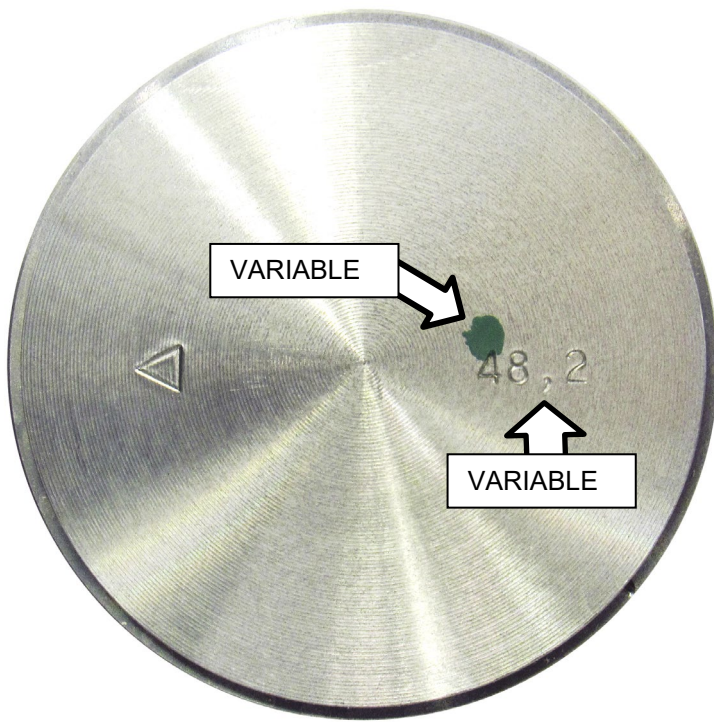
GROOVED PIN

INLET SILENCER - "IAME" IDENTIFICATION MARKING





### PISTON IDENTIFICATION MARKING



### ALTERNATIVE PISTON IDENTIFICATION MARKING

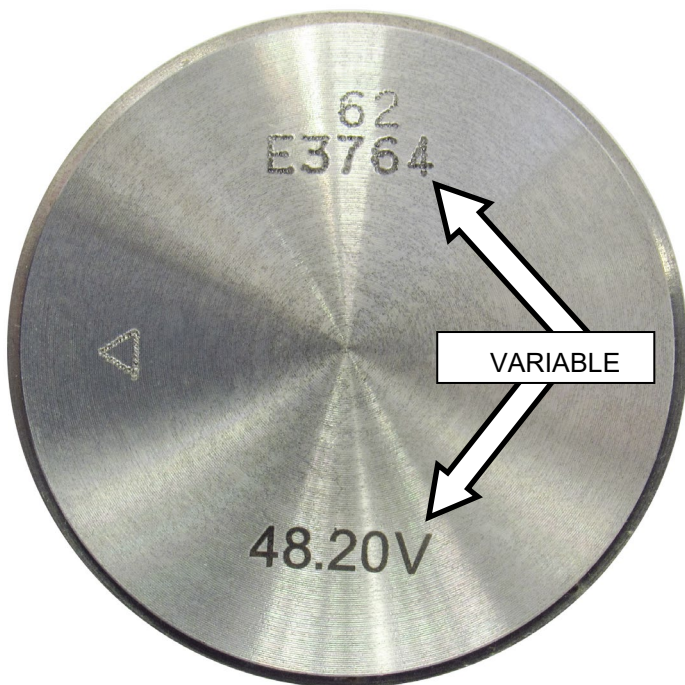
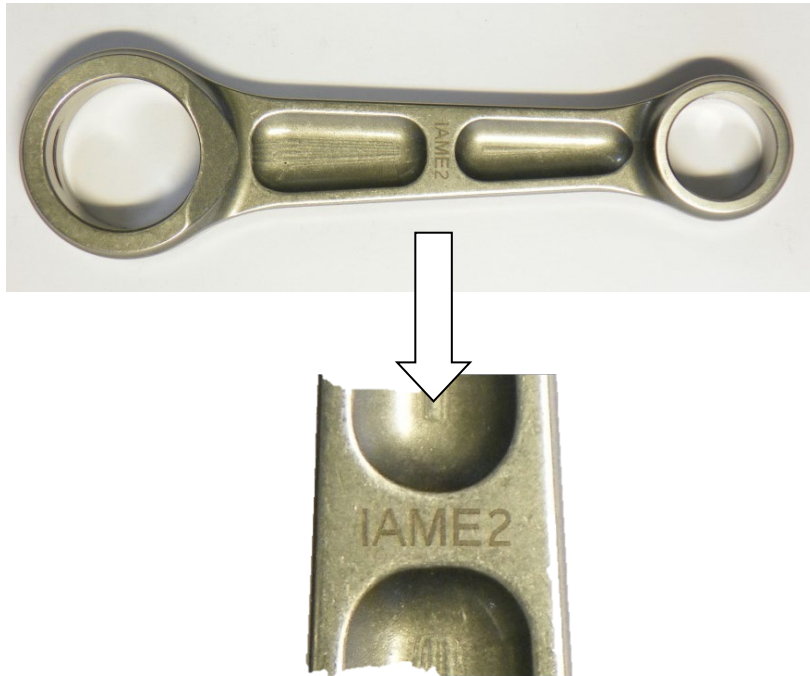
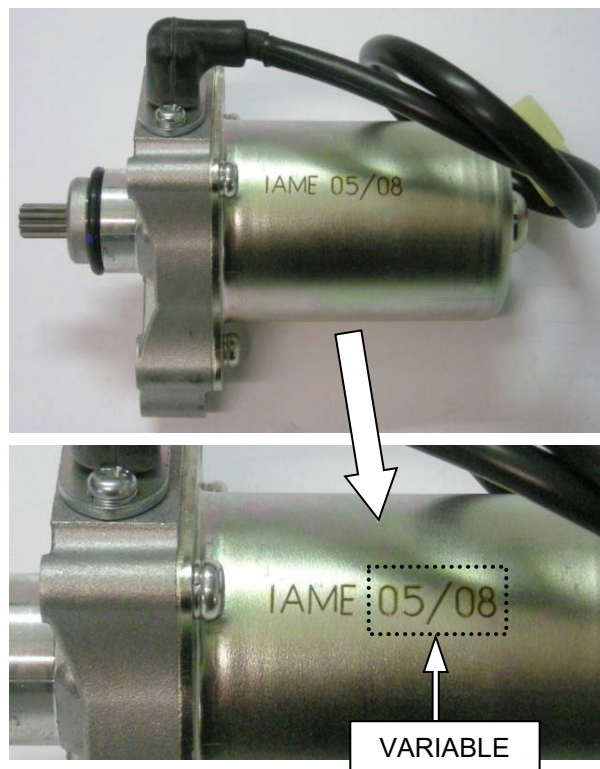


PHOTO IDENTIFICATION CONROD



STARTER IDENTIFICATION MARKING

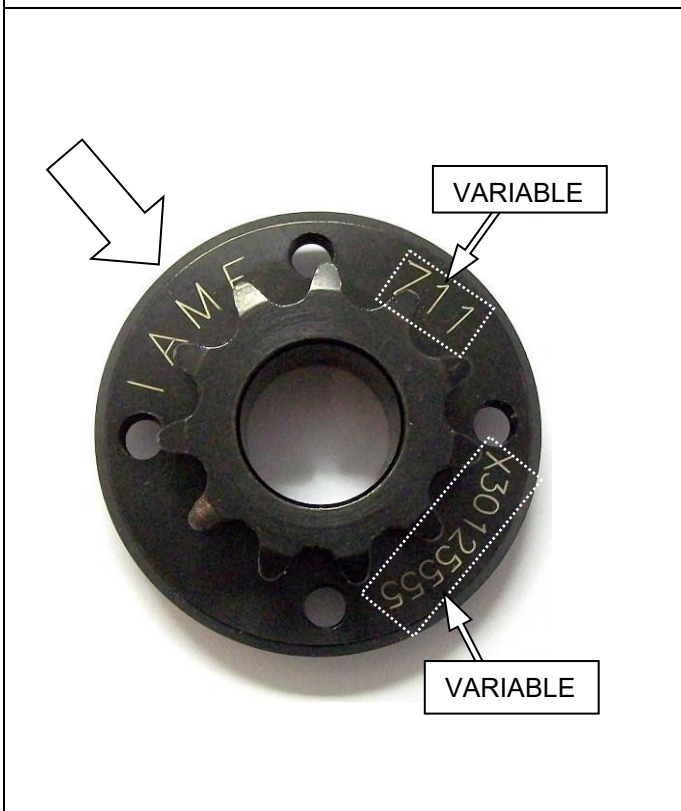




CRANKSHAFT IDENTIFICATION MARKING



SPROCKET IDENTIFICATION MARKING



STARTER RING IDENTIFICATION MARKING



CLUTCH BODY IDENTIFICATION MARKING



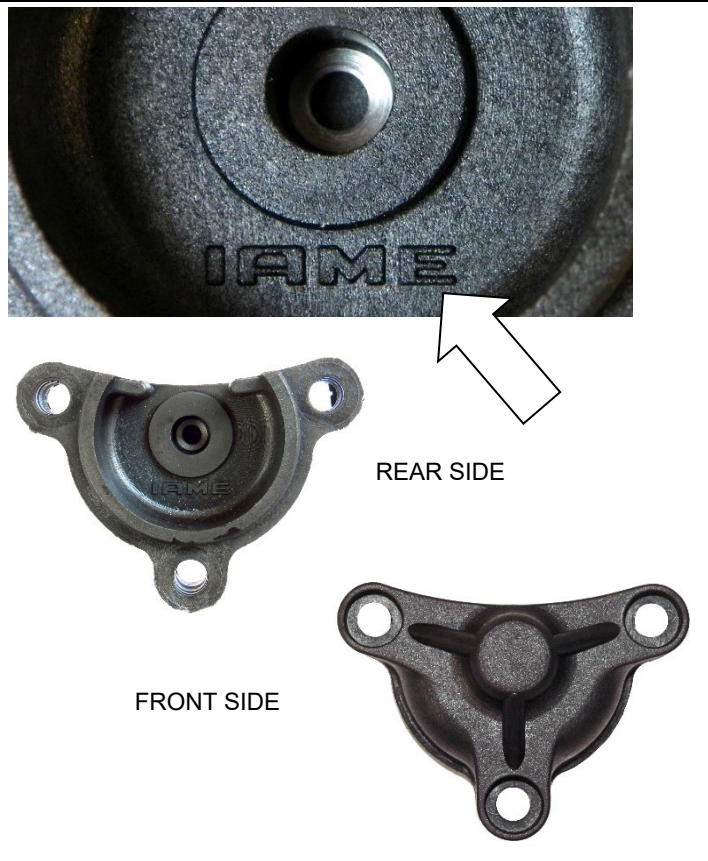
CLUTCH DRUM IDENTIFICATION MARKING



PHOTO IDENTIFICATION CARBURETOR INLET CONVEYOR

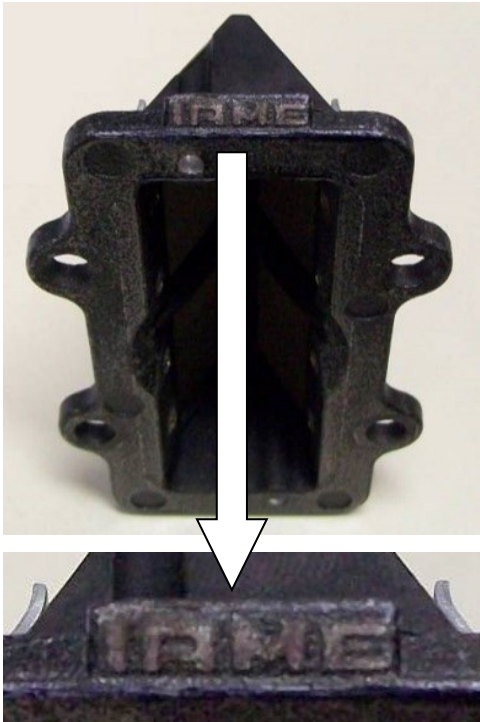


BENDIX COVER IDENTIFICATION MARKING

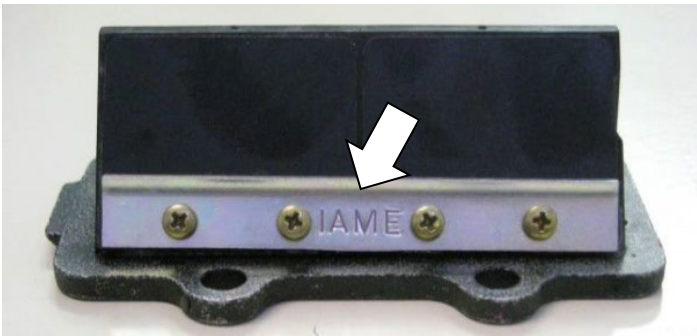
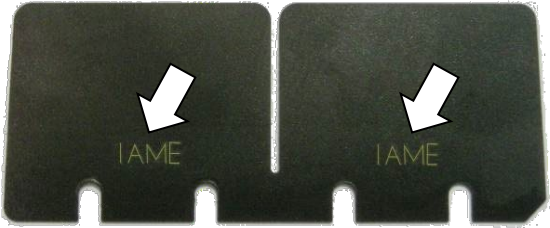




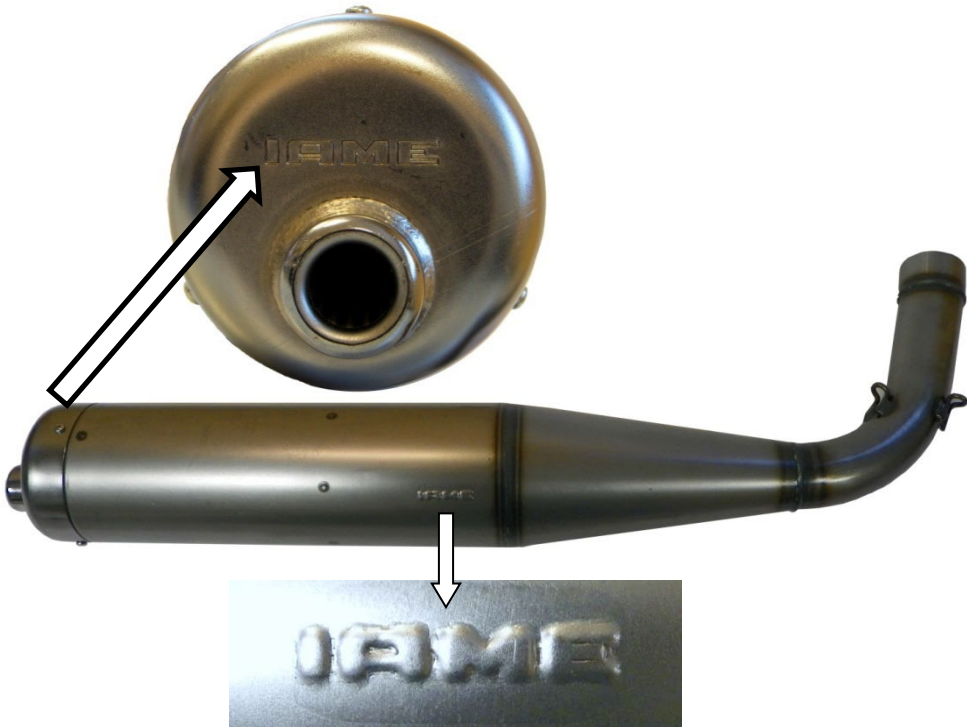
REED GROUP & PETALS IDENTIFICATION MARKING



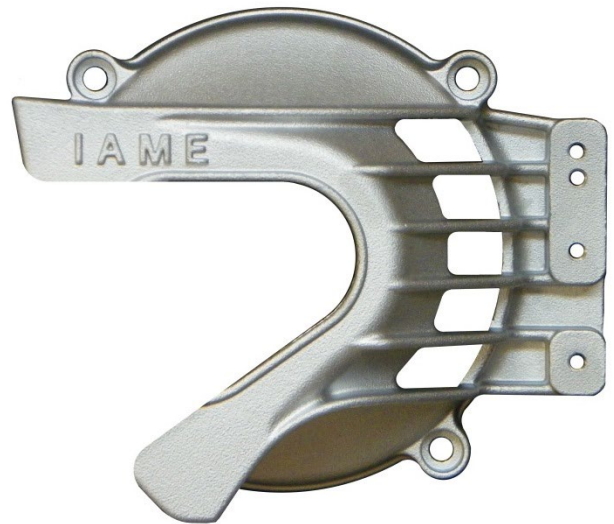
FIBER GLASS



EXHAUST SILENCER IDENTIFICATION MARKING



CLUTCH COVER - ALTERNATIVE SHAPE AND SURFACE FINISHING



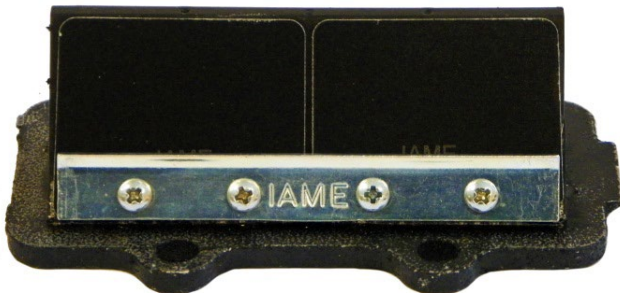
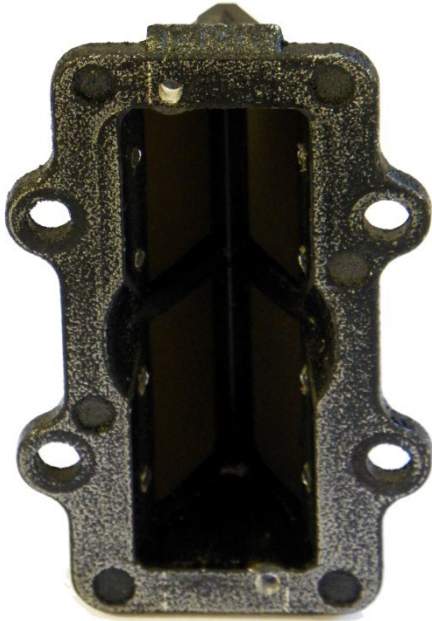
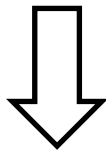
**ALTERNATIVE**



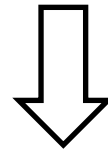


PHOTO IDENTIFICATION REED GROUP

CURRENT VERSION

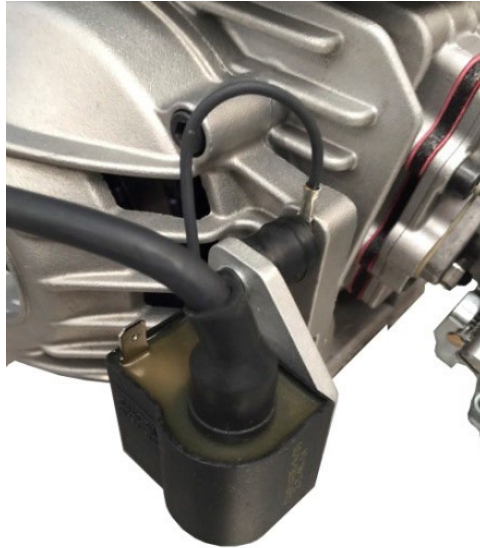


ALTERNATIVE VERSION



ALTERNATIVE INSTALLATION OF GROUND CABLE ON THE CRANKCASE

**STANDARD INSTALLATION**



**ALTERNATIVE INSTALLATION**





**CARBURETTOR**  
**Tillotson HW-33A**

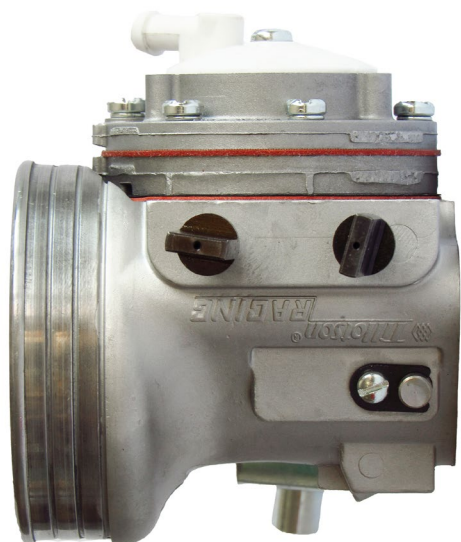


PHOTO OF ADJUSTING SIDE

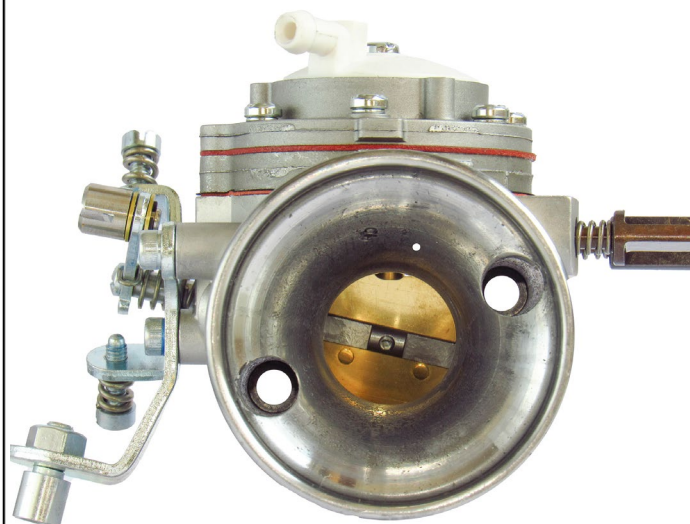
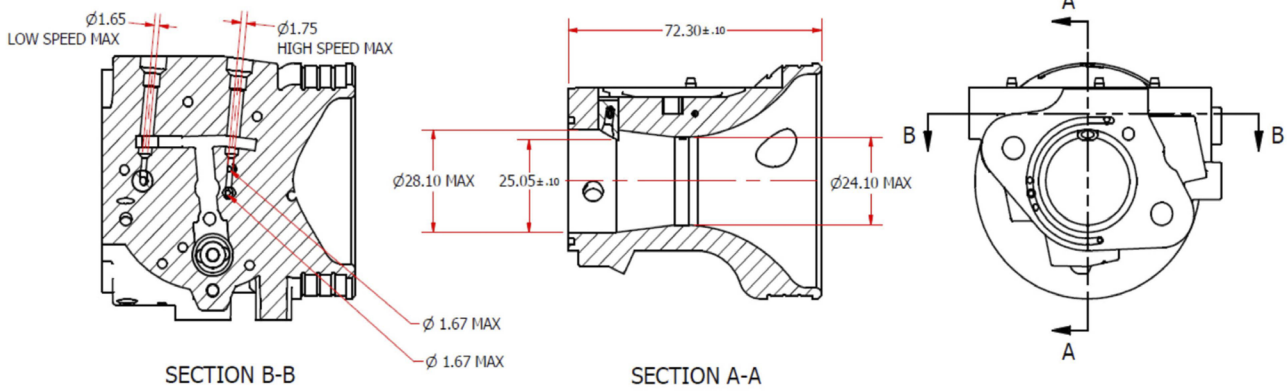


PHOTO OF INLET SIDE

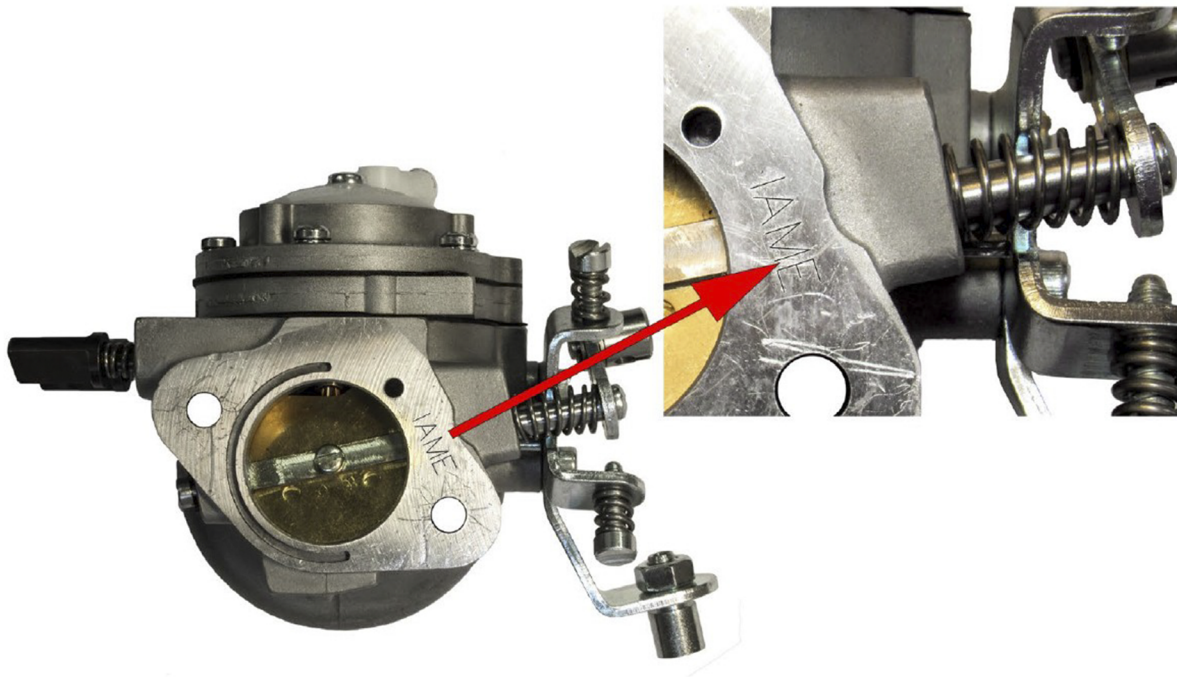
Manufacturer	TILLOTSON LTD.
Make	TILLOTSON
Model	HW-33A



## SECTION VIEW

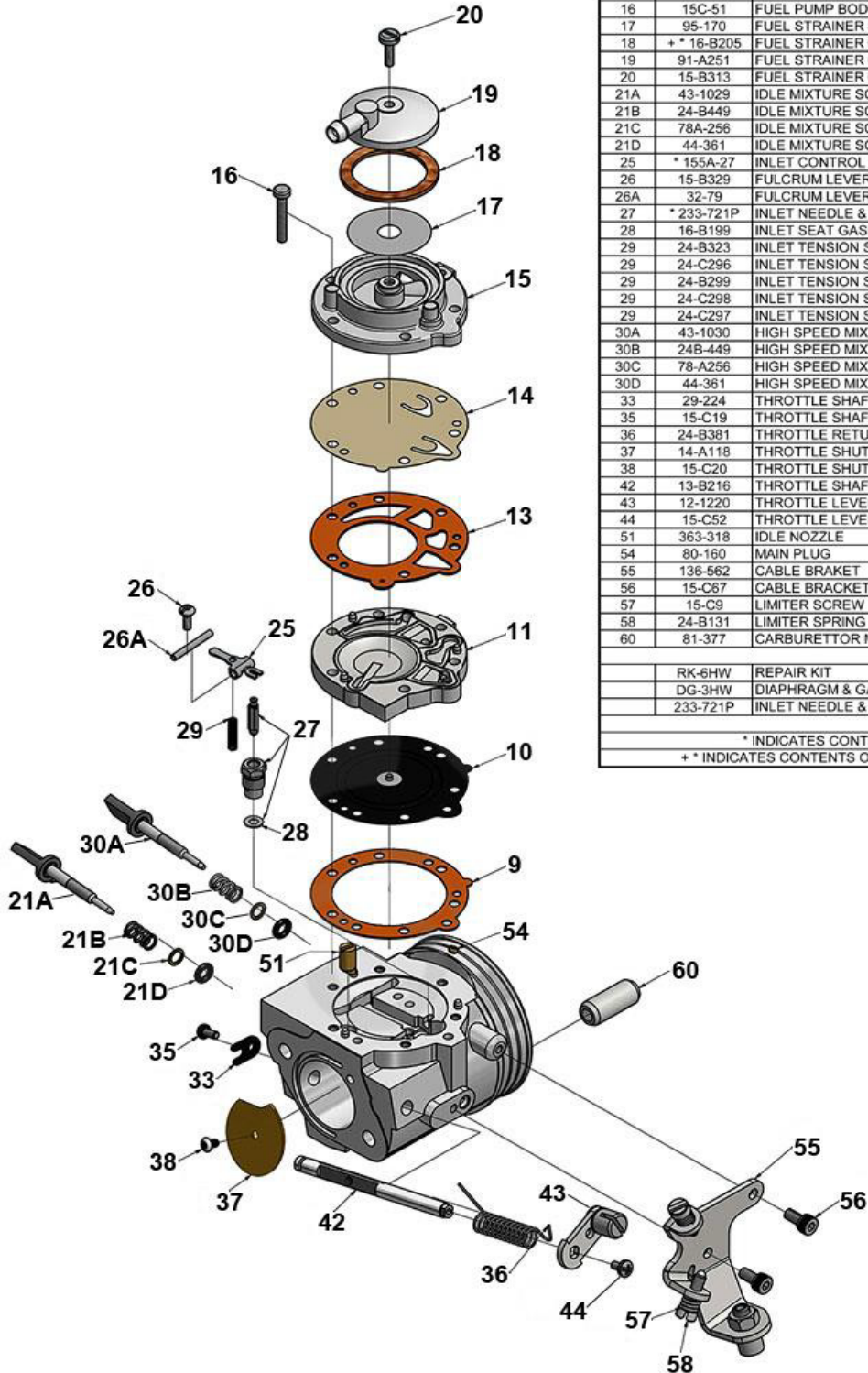


## MARKING



# CARBURETTOR DESCRIPTION AND SKETCH OF PARTS

HW-33A



HW-33A CARBURETTOR PARTS LIST			
ITEM	PART NO:	DESCRIPTION	QTY
9	+ * 16-B406	DIAPHRAGM GASKET	1
10	+ * 237-600	DIAPHRAGM	1
11	91A-275	DIAPHRAGM COVER	1
13	+ * 16-B407	FUEL PUMP GASKET	1
14	+ * 237-162	FUEL PUMP DIAPHRAGM	1
15	141-89	FUEL PUMP BODY	1
16	15C-51	FUEL PUMP BODY SCREW	6
17	95-170	FUEL STRAINER SCREEN	1
18	+ * 16-B205	FUEL STRAINER COVER GASKET	1
19	91-A251	FUEL STRAINER COVER	1
20	15-B313	FUEL STRAINER COVER RETAINING SCREW	1
21A	43-1029	IDLE MIXTURE SCREW	1
21B	24-B449	IDLE MIXTURE SCREW SPRING	1
21C	78A-256	IDLE MIXTURE SCREW WASHER	1
21D	44-361	IDLE MIXTURE SCREW PACKING	1
25	* 155A-27	INLET CONTROL LEVER	1
26	15-B329	FULCRUM LEVER SCREW	1
26A	32-79	FULCRUM LEVER PIN	1
27	* 233-721P	INLET NEEDLE & SEAT SET	1
28	16-B199	INLET SEAT GASKET	1
29	24-B323	INLET TENSION SPRING 26G	OPTION
29	24-C296	INLET TENSION SPRING 31G	OPTION
29	24-B299	INLET TENSION SPRING 37G	1
29	24-C298	INLET TENSION SPRING 42G	OPTION
29	24-C297	INLET TENSION SPRING 46G	OPTION
30A	43-1030	HIGH SPEED MIXTURE SCREW	1
30B	24B-449	HIGH SPEED MIXTURE SCREW SPRING	1
30C	78-A256	HIGH SPEED MIXTURE SCREW WASHER	1
30D	44-361	HIGH SPEED MIXTURE SCREW PACKING	1
33	29-224	THROTTLE SHAFT CLIP	1
35	15-C19	THROTTLE SHAFT CLIP RETAINING SCREW	1
36	24-B381	THROTTLE RETURN SPRING	1
37	14-A118	THROTTLE SHUTTER	1
38	15-C20	THROTTLE SHUTTER SCREW	1
42	13-B216	THROTTLE SHAFT	1
43	12-1220	THROTTLE LEVER ASSEMBLY	1
44	15-C52	THROTTLE LEVER RETAINING SCREW	1
51	363-318	IDLE NOZZLE	1
54	80-160	MAIN PLUG	2
55	136-562	CABLE BRACKET	1
56	15-C67	CABLE BRACKET RETAINING SCREW	2
57	15-C9	LIMITER SCREW	2
58	24-B131	LIMITER SPRING	2
60	81-377	CARBURETTOR MOUNTING NUT	2
RK-6HW		REPAIR KIT	
DG-3HW		DIAPHRAGM & GASKET	
233-721P		INLET NEEDLE & SEAT SET	
* INDICATES CONTENTS OF REPAIR KIT			
+ * INDICATES CONTENTS OF DIAPHRAGM & GASKET SET			



Clash Industrial Estate - Tralee - Ireland  
www.tillotson-racing.com

PARTS OF CARBURETTOR

REF.9 - P. N°16-B406  
DIAPHRAGM GASKET (ORANGE COLOR)



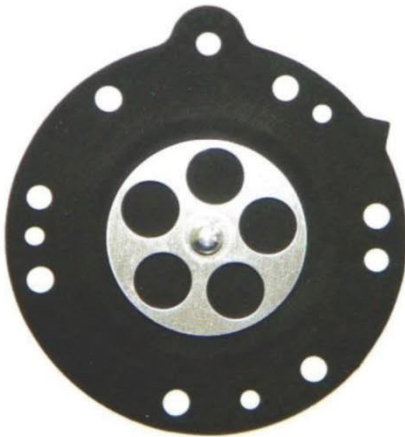
Thickness =  $0.5 \pm 0.1$  mm

REF.13 - P. N° 16-B407  
PUMP DIAPHRAGM GASKET (ORANGE COLOR)



Thickness =  $0.8 \pm 0.1$  mm

REF.10 - P. N°237-600  
DIAPHRAGM



Thickness =  $0.13 \pm 0.07$  mm

REF.14 - P. N°237-162  
PUMP DIAPHRAGM



Thickness =  $0.10 \pm 0.063$  mm

REF.11 - P. N° 91-A275  
DIAPHRAGM COVER



Thickness =  $6.75 \pm 0.15$  mm

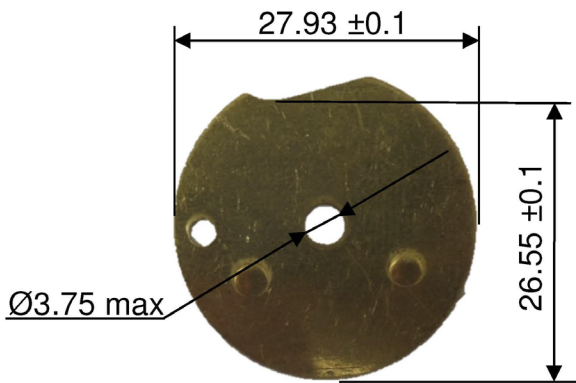
REF.15 - P. N° 141-89  
PUMP COVER



Thickness =  $12.5 \pm 0.15$  mm

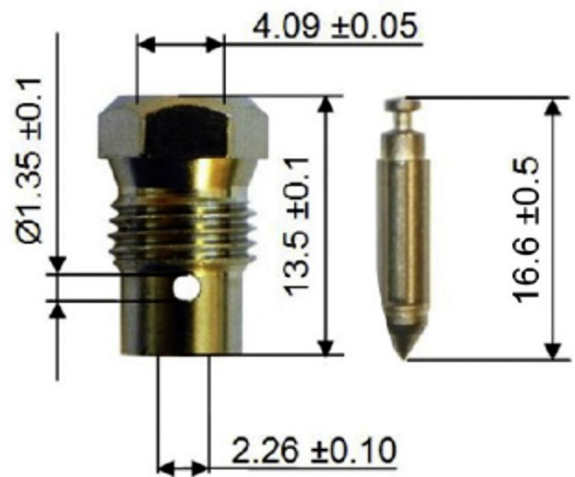


REF.37 - P. N° 14-A118  
THROTTLE SHUTTER

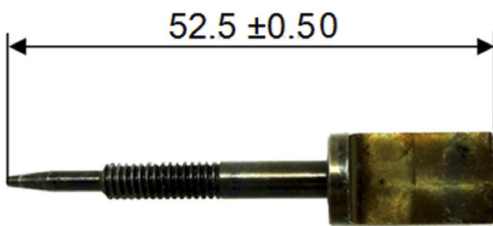


Thickness =  $0.84 \pm 0.1$  mm

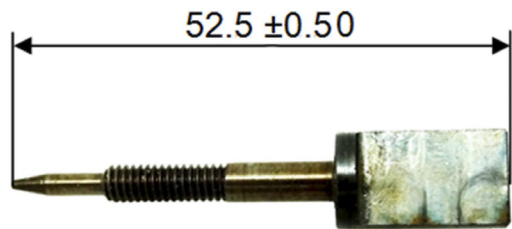
REF.27 - P. N° 233-721P  
SEAT + NEEDLE



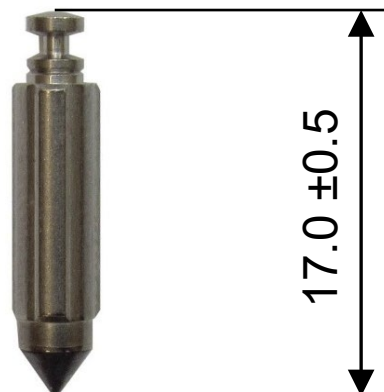
REF.21A - P. N° 43-1029  
NEEDLE LOW SPEED



REF.30A - P. N° 43-1030  
NEEDLE HIGH SPEED

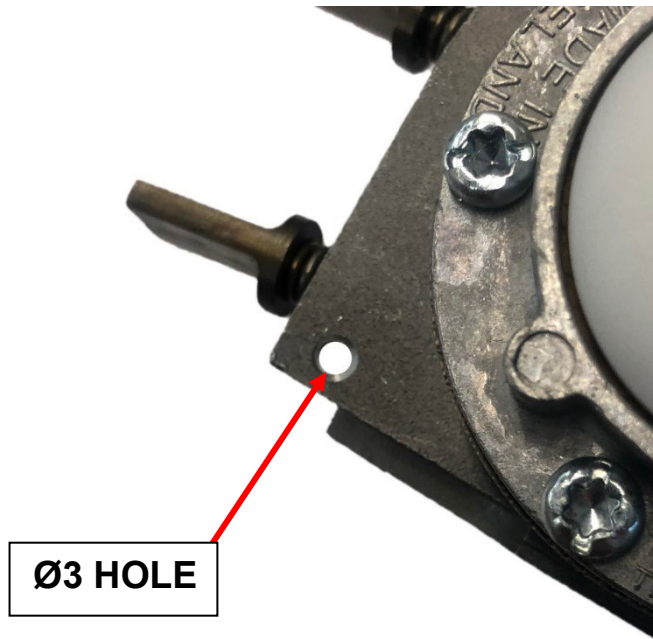


ALTERNATIVE FUEL NEEDLE

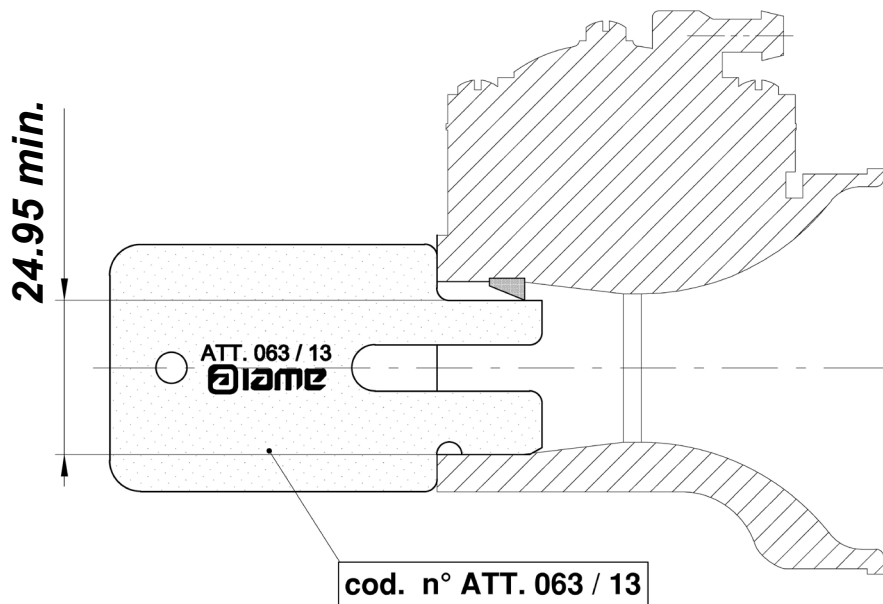


## HOLE FOR CARBURETTOR SEALING

The carburettor can have this hole for sealing

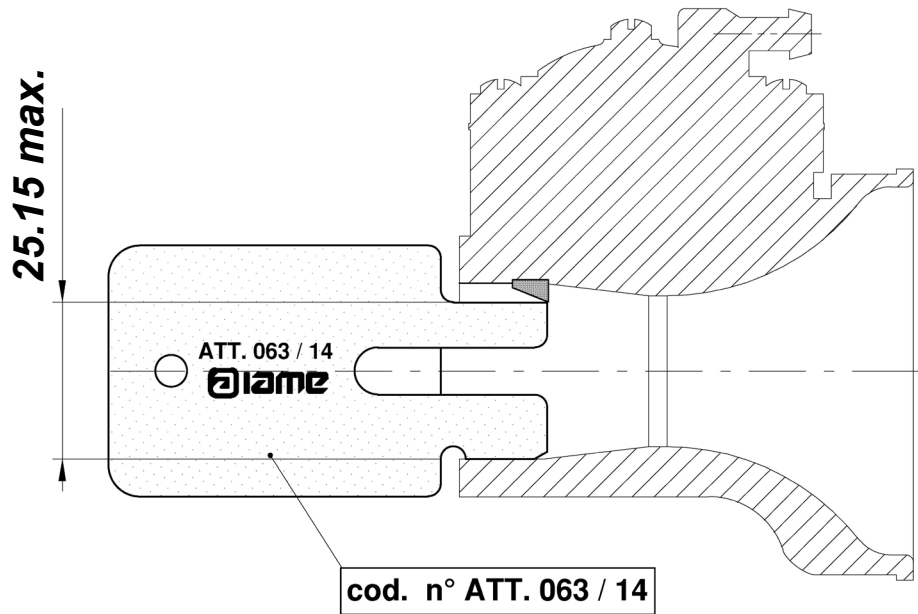


## ATOMIZER – HEIGHT MINIMUM AND CHECKING TOOL

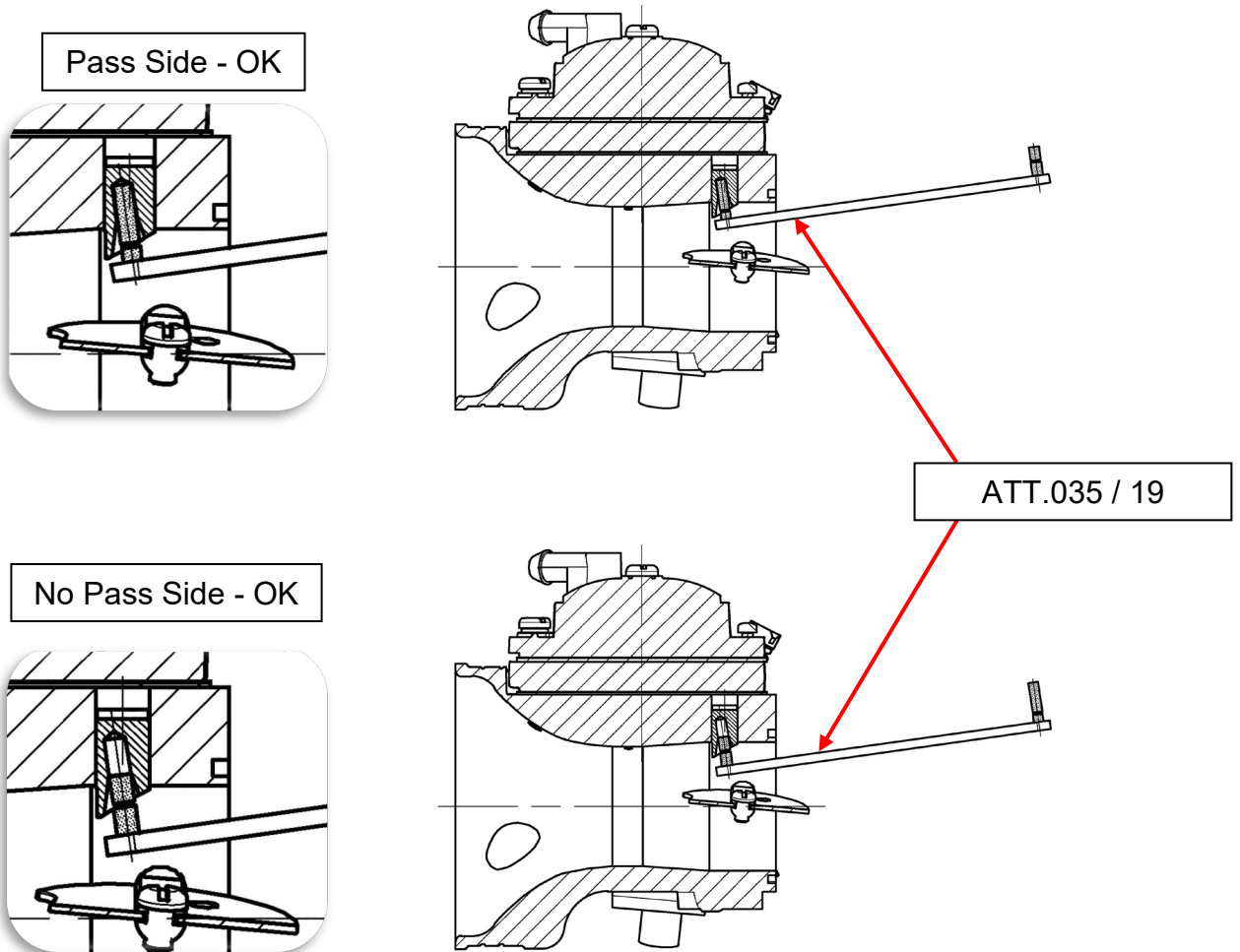




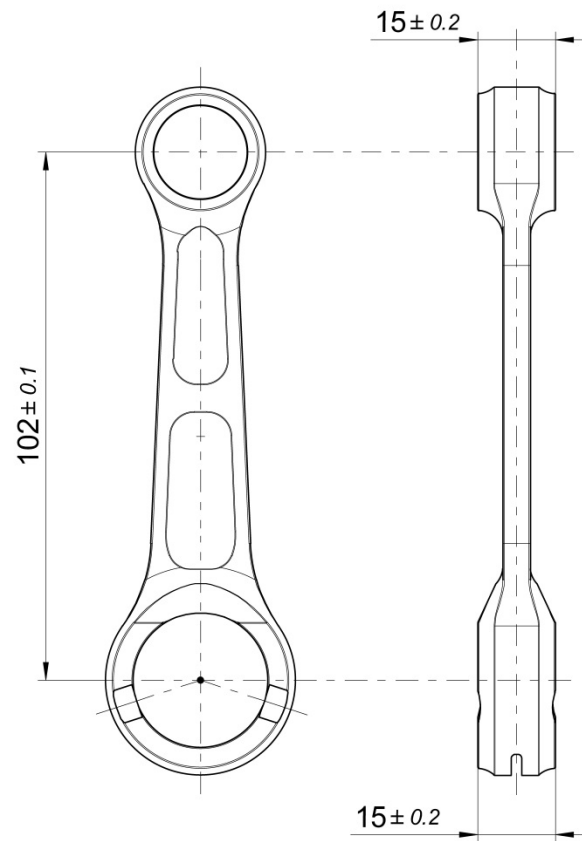
ATOMIZER – HEIGHT MAXIMUM AND CHECKING TOOL



ATOMIZER - CHECKING HOLE DIMENSIONS TOOL



ALTERNATIVE CONROD



BOTH TYPES OF CONROD CAN BE USED WITH BOTH TYPES OF WASHERS  
(IN COUPLE)

PHOTO OF THE CONROD BOTH SIDE – ALTERNATIVE

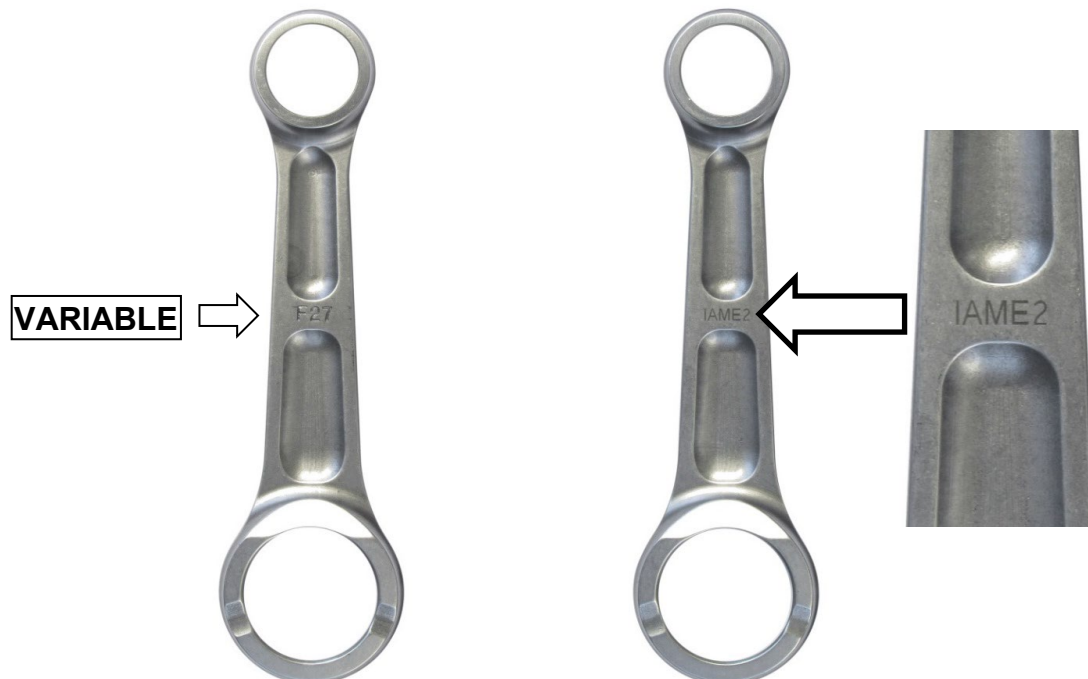


PHOTO IDENTIFICATION OF SMALL END CONROD BEARING – TYPES ALTERNATIVE

TYPE 1



TYPE 2



PHOTO IDENTIFICATION OF SILVER CONROD WASHER – TYPES ALTERNATIVE

TYPE 1



TYPE 2



PARTICULARS WITH ALTERNATIVE NEW LOGO "IAME"

CYLINDER HEAD



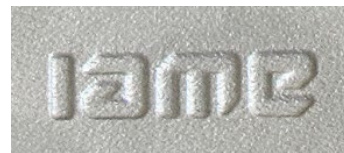
NEW LOGO



CYLINDER



NEW LOGO



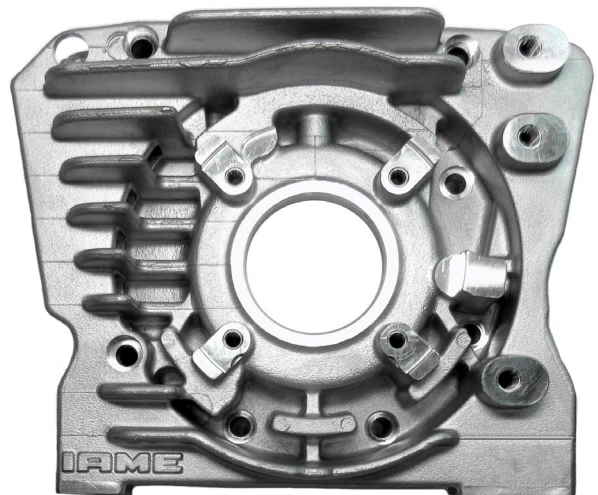
SEMICARTER TRANSMISSION SIDE



NEW LOGO



SEMICARTER IGNITION SIDE



NEW LOGO





PARTICULARS WITH ALTERNATIVE NEW LOGO "IAME"

STARTER SUPPORT



NEW LOGO



CLUTCH COVER



NEW LOGO



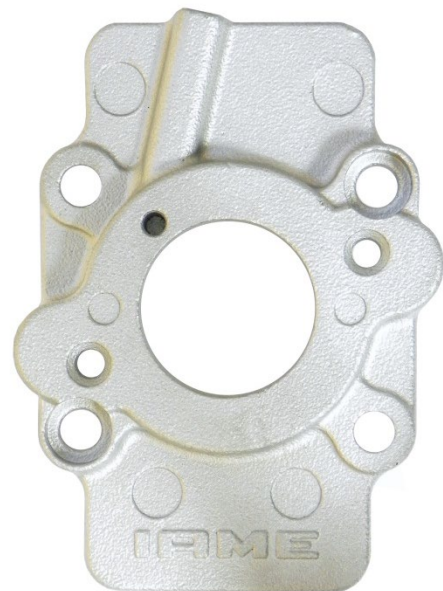
REED GROUP



NEW LOGO



CARBURETTOR INLET CONVEYOR



NEW LOGO



PARTICULARS WITH ALTERNATIVE NEW LOGO "IAME"

EXHAUST



NEW LOGO



NEW LOGO



INLET SILENCER



NEW LOGO



PARTICULARS WITH ALTERNATIVE NEW LOGO "IAME"

**THE OTHERS COMPONENTS OF ENGINE THAT ARE MARKED (LASER OR PUNCHING) UNTIL TODAY WITH LOGO OR WRITTEN "IAME"**

I A M E

or

**IAME**

**NOW COULD BE MARKED WITH NEW LOGO "IAME"**

I a m e

or

Ⓜ I a m e

or

Ⓜ